

# NETZSCH

Proven Excellence.



## Accessories for Laser Flash Analysis

Sample Holders, Accessories and Reference Materials for LFA 447 *NanoFlash*<sup>®</sup>, LFA 467 *HyperFlash*<sup>®</sup>, LFA 467 HT *HyperFlash*<sup>®</sup>, LFA 457 *MicroFlash*<sup>®</sup> and LFA 427

Analyzing & Testing

# Introduction

## Accessories for Laser Flash Analysis

The Laser Flash (LFA) method is a widely used and well established technique for measuring thermal diffusivity. Major advantages of this technique are its high measurement speed and its ability to be applied over a wide temperature and thermal diffusivity range.

Recent years have seen a steady rise in the number and types of materials used in various state-of-the-art applications. Such developments have made it increasingly important to be knowledgeable about the thermophysical properties of these materials – especially their thermal diffusivity and thermal conductivity.

In order to arrive at determinations regarding the thermophysical properties of such materials, special sample preparation and measurement set-up are often required.

NETZSCH accessories can open up a world of possibilities for your thermophysical properties (TPP) needs. It is our hope that this catalogue will serve to acquaint you with these. It provides an overview of accessories and sample holders available for the NETZSCH LFA 447 *NanoFlash*®, LFA 457 *MicroFlash*®, LFA 467 *HyperFlash*® and LFA 427 systems.

If you have any questions, or if you require something specific which you cannot find in the following tables, please simply contact us – NETZSCH welcomes the challenge of working out a solution tailored to your application, and we are always happy to hear from you.

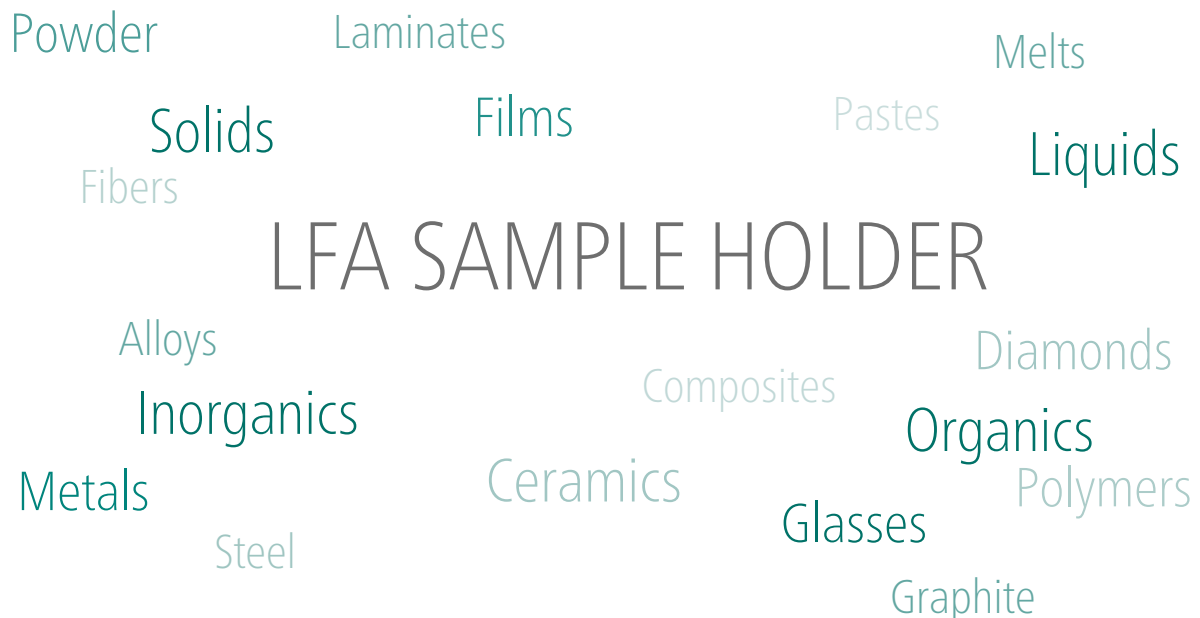

## LFA 447 NanoFlash®

Sample Holders for Round and Square Samples .....	4
Sample Holders for Special Applications .....	6

## LFA 467 HyperFlash®

Sample Holders for Round and Square Samples .....	8
Sample Holders for Special Applications .....	11
Accessories and Spare Parts for Cooling Devices, Furnaces, Tools, Adapters ....	12

## LFA 467 HT HyperFlash®

Sample Holders for Round and Square Samples and Tools .....	14
---	----

## LFA 457 MicroFlash®

Sample Holders for Round and Square Samples, LN <sub>2</sub> Refilling System .....	16
Sample Holders for Special Applications .....	18

## LFA 427

Sample Holders for Different Furnace Types .....	22
Spare Parts for Sample Holders / Sample Supports .....	24
Sample Holders Made of Graphite and for Special Applications .....	26

## Applications:

Sample Holders for Special Applications .....	30
---	----

## Reference Materials

.....	42
-------	----

## Sample Preparation

.....	46
-------	----

## Expertise in Service

.....	47
-------	----

# TABLE OF CONTENTS

LFA 447 NanoFlash®

LFA 467 HyperFlash®

LFA 467 HT HyperFlash®

LFA 457 MicroFlash®

LFA 427

# LFA 447 NanoFlash®

## Sample Holders for Round and Square Samples

Many researchers worldwide have already become convinced of the virtues of the LFA 447 NanoFlash®. Over the years, the application range of this easy-to-operate flash method instrument has been expanded by the addition of many accessories such as sample holders and reference materials.

The following tables are intended to provide an overview of all of the available sample holders for liquids and solids. A variety of sample holders for different sample dimensions and measurements under pressure are included as well.



LFA 447 NanoFlash®

LFA 447 NanoFlash® – Sample Holders and Masks for Round Samples

Sample Holders Inset Diameter	Remarks	Order Number Sample Holder	Mask Orifice Diameter	Order Number Mask
25.4 mm	Sample holder for large samples, mask required	NIB006451	20.4 mm	NIB006805
12.7 mm	<b>Recommended standard</b> sample holder, mask required	NIB006452	9.8 mm	NIB006806
10.0 mm	Sample holder requires mask	NIB007038	7.8 mm	NIB007593
8.0 mm	Sample holder requires mask	NIB007699	6.0 mm	NIB007594
8.0 mm	Sample holder requires mask	NIB007420	4.0 mm	NIB007953

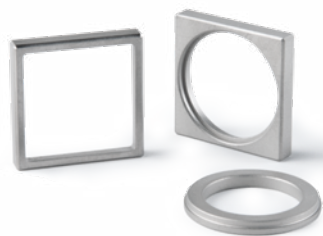

Sample holders and mask for large round and square samples – 25.4 mm



Sample holders and mask for round, square and laminated samples – 12.7 mm

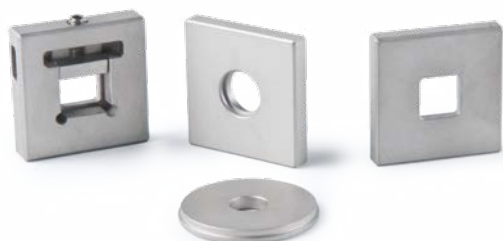

Sample holders and mask for round, square and laminated samples – 10.0 mm



Sample holders and mask for round and square samples – 8.0 mm

#### LFA 447 NanoFlash® – Sample Holders and Masks for Square Samples

Sample Holders Inset Diameter	Remarks	Order Number Sample Holder	Mask Orifice Diameter	Order Number Mask
25.4 mm	Sample holder for large samples, mask required	NIB007418	20.4 mm	NIB006805
12.7 mm	<b>Recommended standard</b> sample holder, mask required	NIB007115	9.8 mm	NIB006806
10.0 mm	Sample holder requires mask	NIB007039	7.8 mm	NIB007593
8.0 mm	Sample holder requires mask	NIB006790	6.0 mm	NIB007594
8.0 mm	Sample holder requires mask	NIB007790	4.0 mm	NIB007953

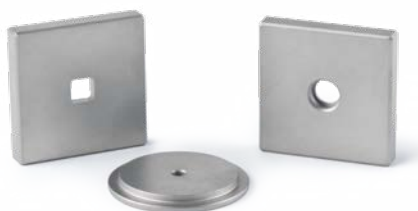

Sample holders and mask for round and square samples – 6 mm

LFA 447 NanoFlash® – Sample Holders and Masks for Special Applications

Sample Holders	Remarks/Sample Dimensions	Order Number Sample Holder	Order Number Mask
Sample holder for customer-specific sample size	Customer-specified sample sizes up to a diameter of 25.4 mm. Note: Smallest practical sample size is 4 to 5 mm. Mask required; diameter depends on sample size.	NIB/447-SH-spc	Please order next smaller mask; special sizes on request
Pressure sample holder	Including torque wrench for 60 ... 260 Ncm Pressure up to 5 MPa. (Use of this sample holder requires the application of 3-layer analysis, which is included in the LFA standard software.)	6.257.1-91.1	
Sample holder for lamellar samples	Sample dimension 10.0 mm x 10.0 mm; mask required	NIB008506	NIB007593
Sample holder for lamellar samples	Sample dimension 12.7 mm x 12.7 mm; mask required	NIB008503	NIB006806
Set for in-plane measurements	Sample holder set consisting of sample holder and mask, sample dimensions of a diameter of 20 mm ... 25.4 mm; thickness of max. 1 mm; mask can be ordered separately. A reference sample for in-plane tests made of graphite (diameter of 25.4 mm x 0.6 mm, order no. NIB007657) is available but not necessarily required.	NIB008171 incl. mask	NIB000425

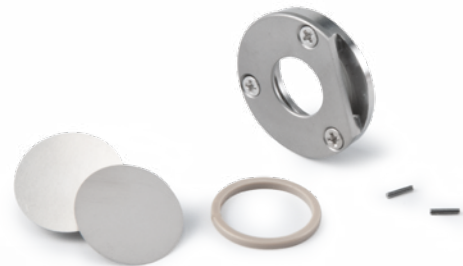

Sample holder for low-viscosity liquids ("PEEK"), order no. 6.256.4-92.7.00



Pressure sample holder with torque wrench, order no. 6.257.1-91.1



Sample container made of Al, specifically for easy preparation of waxes, order no. 6.256.4-91.6.00

### LFA 447 NanoFlash® – Special Sample Holders for Liquids

Sample Holders	Remarks/Sample Dimensions	Order Number
Sample container for liquids ("Waxes")	Specifically for easy preparation of wax samples; made of Al 99.9 with lid; for sample holder with a diameter of 12.7 mm (NIB/006452); RT ... 300°C.	6.256.4-91.6.00
Sample holder for liquids ("PEEK")	For measurements on liquids (water, oils), pastes, resins and polymer melts up to about 250°C; consisting of reusable stainless steel frames and 5 sets of disposable parts (stainless steel, PEEK); replaceable. Sample dimensions of a diameter of 15 mm x 1.5 mm. Sample is applied by means of cannula via a bore hole (diameter of 1 mm). Please see scheme of spare parts on page 28.	6.256.4-92.7.00
Spare parts for 6.256.4-92.7.00		
Spare parts for the sample holder for liquids ("PEEK")	<ul style="list-style-type: none"> <li>■ Sample holding ring made of PEEK; sample thickness of 1.5 mm</li> <li>■ Sample cover disk made of stainless steel 1.4301; diameter of 18 x 0.1 mm</li> <li>■ Locking pins made of stainless steel; diameter of 1 x 5 mm; 20 pieces</li> </ul>	NGB812943 NGB812552 6.256.4-92.7.06
Sample pan for liquid metals and highly conductive powders ("Sapphire-S")	Made of sapphire, pan with lid, sample support and threaded cap of stainless steel, sample dimension of a diameter of 11 mm x 1.5 mm	6.256.4-91.7

### Spare and Wear Parts

Sample Holders	Remarks	Order Number
Window	Made of sapphire, upper window (one of four) furnace	NIB006337
Window	Made of Borofloat glass, 4" x 4", lower furnace window	NIB007077
Extractor	For sample holder	2.256.2-16.0.00
Flash lamp module	With Xenon flash lamp and cable	2.256.2-07.5.00
Graphite spray <sup>1)</sup>	200 ml; for sample coating	GB396352
Funnel	For filling LN <sub>2</sub> in the detector	NGB803463

1) Due to existing freight regulation, this spray must be marked as hazardous materials when shipped. Therefore, this item will be in a separate hazardous materials shipment which will generate considerably additional costs.



Sample holder for lamellar samples, order no. NIB008506

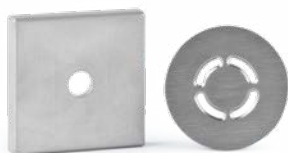

LFA 447 sample holder for in-plane tests, order no. NIB008171



Sample pan for liquid metals and highly conductive powders, order no. 6.256.4-91.7

# LFA 467 HyperFlash®

## LFA 467 HyperFlash® – Sample Holders and Accessories

The LFA 467 HyperFlash® features a sample changer for up to 16 samples which enables effective, high sample throughput. A tray for four sample holders can be used for round and square samples. Each of the four sample holders can carry up to four samples with a maximum diameter of 12.7 mm each. The sample dimensions can be round or square. For measurements on large samples, inserts are available which can accommodate a sample diameter of up to 25.4 mm. Depending on the sample's properties, its thickness can vary between 0.01 mm and 6 mm.

In addition to standard sample holders for solid samples of round and square geometries, we also offer sample holders designed for special applications on specific materials, including:

- Molten polymers and low-viscosity liquids
- Resins during curing
- Pastes and powders
- Fibers
- Laminates



LFA 467 HyperFlash®



Standard sample holder, 12.7 mm diameter, order no. LFA46700A90.011-00



Standard sample holder, 10.0 mm diameter, order no. LFA46700A90.012-00



Standard sample holder, 8.0 mm diameter, order no. LFA46700A90.013-00



Standard sample holder, 6.00 mm diameter, order no. LFA46700A90.014-00





Standard sample holder, 25.4 mm diameter,  
order no. LFA46700A90.021-00



Standard sample holder, 12.7 mm diameter,  
order no. LFA46700A90.022-00



Standard sample holder, 10.0 mm diameter,  
order no. LFA46700A90.023-00



Standard sample holder, 6.00 mm diameter,  
order no. LFA46700A90.025-00



Standard sample holder, 8.00 mm diameter,  
order no. LFA46700A90.024-00



Standard sample holder with masks

LFA 467 HyperFlash® – Standard Sample Holder Set for Round Samples

Sample Holders Inset Diameter	Remarks	Order Number Sample Holder	Order Number Component Part		
			Sample Holder	Cover Disk*	Mask**
12.7 mm	For 4 samples, incl. 4 cover disks	LFA46700A90.011-00 LFA46700A90.011-00	NGB814357	NGB814394	NGB815891 (optional)
10.0 mm	For 4 samples, incl. 4 cover disks	LFA46700A90.012-00	NGB814358	NGB814406	NGB815890 (optional)
8.0 mm	For 4 samples incl. 4 cover disks and 4 masks	LFA46700A90.013-00	NGB814359	NGB814407	NGB814386
6.0 mm	For 4 samples incl. 4 cover disks and 4 masks	LFA46700A90.014-00	NGB814360	NGB814409	NGB814387
25.4 mm	For 1 sample, incl. 1 cover disk	LFA46700A90.021-00	NGB814361	NGB814403	NGB815889 (optional)
12.7 mm	For 1 sample, incl. 1 cover disk	LFA46700A90.022-00	NGB814362	NGB814394	NGB815891 (optional)
10.0 mm	For 1 sample, incl. 1 cover disk	LFA46700A90.023-00	NGB814363	NGB814406	NGB815890 (optional)
8.0 mm	For 1 sample, incl. 1 cover disk and mask	LFA46700A90.024-00	NGB814364	NGB814407	NGB814386
6.0 mm	For 1 sample, incl. 1 cover disk and mask	LFA46700A90.025-00	NGB814365	NGB814409	NGB814387

\* Cover disk covers vacant sample positions in the sample holder

\*\* Mask is required only for instruments without ZoomOptics



Standard sample holder, 10.0 mm x 10.0 mm, order no. LFA46700A90.031-00



Standard sample holder, 8.0 mm x 8.0 mm, order no. LFA46700A90.032-00



Standard sample holder, 6.0 mm x 6.0 mm, order no. LFA46700A90.033-00



Standard sample holder, 25.4 mm x 25.4 mm, order no. LFA46700A90.041-00



Standard sample holder, 12.7 mm x 12.7 mm, order no. LFA46700A90.042-00

### LFA 467 HyperFlash® – Standard Sample Holder Set for Square Samples

Sample Holders Inset Diameter	Remarks	Order Number Sample Holder	Order Number Component Part		
			Sample Holder	Cover Disk*	Mask**
10.0 mm x 10.0 mm	For 4 samples, incl. 4 cover disks	LFA46700A90.031-00	NGB814366	NGB814410	NGB815890 (optional)
8.0 mm x 8.0 mm	For 4 samples, incl. 4 cover disks and 4 masks	LFA46700A90.032-00	NGB814367	NGB814411	NGB814386
6.0 mm x 6.0 mm	For 4 samples incl. 4 cover disks and 4 masks	LFA46700A90.033-00	NGB814368	NGB814414	NGB814387
25.4 mm x 25.4 mm	For 1 samples incl. 1 cover disks	LFA46700A90.041-00	NGB814369	NGB814412	NGB815889 (optional)
12.7 mm x 12.7 mm	For 1 sample, incl. 1 cover disk	LFA46700A90.042-00	NGB814370	NGB814413	NGB815891 (optional)
10.0 mm x 10.0 mm	For 1 sample, incl. 1 cover disk	LFA46700A90.043-00	NGB814371	NGB814410	NGB815890 (optional)
8.0 mm x 8.0 mm	For 1 sample, incl. 1 cover disk	LFA46700A90.044-00	NGB814372	NGB814411	NGB814386
6.0 mm x 6.0 mm	For 1 sample, incl. 1 cover disk and mask	LFA46700A90.045-00	NGB814373	NGB814414	NGB814387

\* Cover disk covers vacant sample positions in the sample holder

\*\* Mask is required only for instruments without ZoomOptics



Standard sample holder, 10.0 mm x 10.0 mm, order no. LFA46700A90.043-00



Standard sample holder, 8.0 mm x 8.0 mm, order no. LFA46700A90.044-00



Standard sample holder, 6.0 mm x 6.0 mm, order no. LFA46700A90.045-00

## LFA 467 HyperFlash® – Standard Sample Holders for Special Applications: Liquids

Special Sample Holders	Remarks	Order Number
Sample container	For liquids (“Waxes”) Specifically for easy preparation of wax samples; made of Al 99.9 with lid; for sample holder; RT ... 300°C. Adapter for container is required order no. NGB814378	6.256.4-91.6.00
Sample holder for low-viscous liquids (“PEEK”)	For water, oils and fluid resins; can be used up to approx. 250°C; consisting of reusable stainless steel frames and 5 sets of disposable parts; replaceable. Sample dimensions of a diameter of 15 x 1.5 mm. Sample application by means of cannula via borehole, diameter 1 mm. <b>requires LFA46700A90.021-00.</b>	6.256.4-92.7.00
Sample holder for liquid metallic samples (“Sapphire-S”)	Sample support and threaded cap of stainless steel with sample pan and lid of sapphire; especially for liquid metallic and powdery samples, diameter of 11 mm x 1.5 mm; <b>requires LFA46700A90.021-00</b> (sample holder for round samples, diameter 25.4 mm)	6.256.4-92.9.00
Spare parts for the sample holder (“Sapphire-S”)	Sapphire sample pan Sapphire lid	GB396990 GB396991

LFA 467 HyperFlash®



Sample holder for liquids „Sapphire-S”, order no. 6.256.4-92.9.00



Sample holder for liquids “PEEK”, order no. 6.256.4-92.7.00



Sample container made of Al, specifically for easy preparation of waxes, order no. 6.256.4-91.6.00



Sample holder for thick samples, order no. LFA46700A90.086-00

## LFA 467 HyperFlash® – Sample Holders for Special Applications: Thick Samples

### Round Samples, Thickness 2 mm to 6 mm

Diameter	Remarks	Order Number Sample Holder Set	Order Number Component Part		
			Sample Holder	Cover Disk*	Mask**
12.7 mm	1 cover disk, 1 mask	LFA46700A90.086-00	NGB816036	NGB814394	NGB816042

\* Cover disk covers vacant sample positions in the sample holder

\*\* Mask is required only for instruments without *ZoomOptics*

**LFA 467 HyperFlash® – Sample Holders for Special Applications:  
Powders, Fibers, Lamellas, Pressure, In-Plane, Thin and Highly Conductive Samples and Foils**

Special Sample Holders	Remarks	Order Number
Sample holder for powders ("Sapphire-S")	Sample support and threaded cap of stainless steel, with sample pan and lid of sapphire; especially for powders and liquid metallic samples diameter of 11 mm x 1.5 mm; <b>requires LFA46700A90.021-00</b> (sample holder for round samples, diameter 25.4 mm)	6.256.4-92.9.00
Sample holder for fibrous samples	Made of Al <sub>2</sub> O <sub>3</sub> ; consisting of 2 half shells and fixing ring; <b>requires adapter NGB814697</b> and tool set 6.256.1-93.4.00	6.256.1-93.3.00
	Adapter for sample holder 6.256.1-93.3.00	NGB814697
	Tool set for sample preparation of fibers for sample holder 6.256.1-93.3.00	6.256.1-93.4.00
Sample holder for lamellar samples	The single lamellas are compressed to a total sample size of 12.7 mm x 12.7 mm by means of clamping screws.	LFA46700A90.051-00
	The single lamellas are compressed to a total sample size of 10.0 mm x 10.0 mm by means of clamping screws.	LFA46700A90.052-00
Pressure sample holder	Pressure-calibrated sample holder; pressure up to 5 MPa; 3-layer analysis; including torq wrench for 60 to 260 Ncm; max. working temperature 300°C; <b>requires LFA46700A90.021-00</b> (sample holder for round samples, diameter 25.4 mm)	6.257.1-91.9.00
Component parts for pressure sample holder	Disk made of aluminum, for standard applications	6.257.1-91.1.03
	Disk made of sapphire	NGB812117
Sample holder for in-plane measurements	Made of stainless steel; set for in-plane tests on highly conductive materials (samples consisting of sample holder inset and cap; sample dimensions of a diameter 20 mm to 25.4 mm, thickness of max. 1 mm; <b>requires LFA46700A90.021-00</b> (sample holder for round samples, diameter 25.4 mm) and <b>LFA 46700A61.020-00</b> (ZoomOptics) A reference sample made of graphite (diameter of 25.4 mm x 0.6 mm, order no. NIB007657) is available but not necessarily required.	6.257.1-91.2.00
Sample holder for thin samples and foils	Sample dimensions 12.7 mm x 12.7 mm Sample thickness of max. 200µm	LFA46700A90.071-00
Sample holder for thin samples and foils	Sample dimensions 25.4 mm x 25.4 mm Sample thickness of max. 200µm	LFA46700A90.072-00



Sample holder for in-plane measurements, order no. 6.257.1-91.2.00



Sample holder for thin samples and foils, dimensions 12.7 mm x 12.7 mm, order no. LFA46700A90.071-00



Sample holder for thin samples and foils, dimensions 25.4 mm x 25.4 mm, order no. LFA46700A90.072-00

LFA 467 HyperFlash® – Tools, Adapters and LN<sub>2</sub>-Refilling System for the Infrared Detector Head

	Remarks	Order Number
Sample preparation	For fibrous samples; consisting of upper and lower part; guiding disk, supporting ring, threaded rod, knurled nut, gurb screw	6.256.1-93.4
Adapter for sample holder for fibers	For sample holder 6.256.1-93.3.00	NGB814697
Adapter for sample container for lowconductivity liquids	For sample holder 6.256.4-91.6.00	NGB814378

LFA 467 HT HyperFlash® – LN<sub>2</sub>-Refilling System for the Infrared Detector Head

Device	Remark	Order Number
LN <sub>2</sub> -Refilling System	For the detector head, with flexible LN <sub>2</sub> -tubing, length 4 m, 35 liter aluminum dewar, trolley with 5 swivel wheels, supply voltage 115/230 V, 50/60 Hz; for LFA 467, type LFA46700B00.000-00	LFA46700B60.000-00



Sample holder „Sapphire-S“, order no. 6.256.4-92.9.00



Sample holder for lamellar samples, order no. LFA46700A90.052-00



Sample holder for fibrous samples, order no. 6.256.1-93.3.00



Torque wrench for pressure sample holder, included in order no. 6.257.1-91.9.00

# LFA 467 HT *HyperFlash*®

## LFA 467 HT *HyperFlash*® – Sample Holders and Accessories

The LFA 467 HT *HyperFlash*® offers four individual fast-responding mini-tube furnaces for a total of four specimens.

Each mini-tube furnace has its own thermocouple; this design offers a homogeneous temperature distribution across all samples, which is beneficial for determination of the specific heat capacity ( $c_p$ ). In addition, the surrounding area is water-cooled and the entire furnace system has a low thermal mass. The combination of these specific features not only guarantees high sample throughput, but is also a prerequisite for short measurement times. Sample holders can be used for round and square samples with a maximum edge length of 10 mm (square) and diameter of 12.7 mm (round), respectively.



### LFA 467 HT *HyperFlash*® – Standard Sample Holders

Sample Holders Inset Diameter	Remarks	Order Number Sample Holder	Order Number Component Part	
			Sample Holder	Mask
12.7 mm	For one round sample, incl. mask	LFA46700B93.011-00	NGB816418	NGB816419
10.0 mm	For one round sample, incl. mask	LFA46700B93.013-00	NGB816422	NGB816421
10.0 mm x 10.0 mm	For one square sample, incl. mask	LFA46700B93.012-00	NGB816420	NGB816421

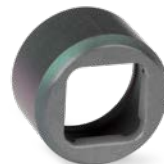

Sample holder, diameter 12.7 mm;  
Order no. LFA46700B93.011-00

Sample holder, diameter 10.0 mm;  
Order no. LFA46700B93.013-00

Sample holder, diameter 10 mm x 10 mm;  
Order no. LFA46700B93.012-00

**LFA 467 HT HyperFlash® – Sample Holder for Liquids and Powders –  
Only for Use in Combination with the InSb Detector**

Special Sample Holder	Remarks	Order Number
Sample holder for liquids (water, oils), pastes, resins and polymer melts ("PEEK")	Incl. a re-usable stainless steel frame and 5 disposable parts (exchangeable, made of stainless steel, PEEK); up to 250°C; nom. sample dimensions $\varnothing$ 9.5 x 1.5 mm	LFA46700B96.010-00
Sample holder for liquid and powdery metallic samples ("Sapphire-S")	Sample support and cap made of stainless steel, with pan and lid made of sapphire; nom. sample dimensions: $\varnothing$ 11 x 1.5 mm, up to 500°C	LFA46700B96.040-00
Sample holder for liquid and powdery metallic samples ("Sapphire-SiC")	Sample support and cap made of SiC, with pan and lid made of sapphire; nom. sample dimensions: $\varnothing$ 11 x 1.5 mm, up to max. 1250°C	LFA46700B96.041-00
Spare parts for sample holder „Sapphire-S“ and “Sapphire-SiC”	Sapphire sample pan Sapphire lid	GB396990 NGB820106



LFA sample holder for liquids and powders (order no. LFA46700B96.040-00), here shown in the stainless steel version.



Mounting tool, order no. NGB816070



Sample holder „PEEK“ for liquids

**LFA 467 HT HyperFlash® – Pressure Sample Holder**

Pressure Sample Holder	Remark	Order Number
Pressure sample holder for powdery samples	Pressure-calibrated sample holder, pressure up to 5 MPa; Including torque wrench for 60 ... 260 Ncm, up to max. 300°C	LFA46700B96.020-00

**LFA 467 HT HyperFlash® – Lamellar Sample Holder**

Lamellar Sample Holder	Remark	Order Number
Lamellar sample holder for polymers and fiber-reinforced plastics	Sample support for lamellar samples via clamping screws for a total sample size of 10 mm x 10 mm, up to max. 600°C	LFA46700B96.030-00

**LFA 467 HT HyperFlash® – Tool**

Tool	Remark	Order Number
Mounting tool for furnace window	For furnace LFA46700B32.000-00	NGB816070

**LFA 467 HT HyperFlash® – LN<sub>2</sub>-Refilling System for the Infrared Detector Head**

Device	Remark	Order Number
LN <sub>2</sub> -Refilling System	For the detector head, with flexible LN <sub>2</sub> -tubing, length 4 m, 35 liter aluminum dewar, trolley with 5 swivel wheels, supply voltage 115/230 V, 50/60 Hz; for LFA 467, type LFA46700B00.000-00	LFA46700B60.000-00

LFA 467 HT HyperFlash®



# LFA 457 *MicroFlash*®

## LFA 457 *MicroFlash*® – Sample Holders and Accessories

A great variety of sample holders accommodating different sample dimensions is available for the state-of-the-art LFA 457 *Micro-Flash*®. Sample holders for special applications – such as measurements on liquids, powders, and laminates, or for in-plane tests – also form part of our range of LFA accessories. The following tables are intended to provide an overview of all of the available sample holders, including those for special applications.



LFA 457 *MicroFlash*®

### LFA 457 *MicroFlash*® – Complete Sample Holder Sets (Inset and Cap) and Spare Parts

Sample Holder Sets	Remarks	Order Number
Set for 3 samples	For 3 samples, consisting of base plate (SiC), 3 sample holder insets made of Al <sub>2</sub> TiO <sub>5</sub> *, for sample sizes of a diameter of 12.7 mm; 3 caps (SiC) and 3 sealing washers	6.257.1-90.1.00
Base plate for 3 sample	Made of SiC, for samples of a diameter of 12.7 mm	NGB803741
Sealing washer	Made of SiC, for sample holders of a diameter of 12.7 mm	NGB803807
Set for 1 sample	For 1 sample, consisting of base plate (SiC), sample inset made of Al <sub>2</sub> TiO <sub>5</sub> *, for sample sizes of a diameter of 25.4 mm	6.257.1-90.2.00
Base plate for 1 sample	Made of SiC, for sample of a diameter of 25.4 mm	NGB803735

\* Al<sub>2</sub>TiO<sub>5</sub> = aluminum titanate



Complete sample holder set for 3 samples



Complete sample holder set for one large sample (diameter of 25.4 mm)

### LFA 457 *MicroFlash*® – LN<sub>2</sub>-Refilling System for the Infrared Detector Head

Device	Remark	Order Number
LN <sub>2</sub> -Refilling System	LN <sub>2</sub> -Refilling system for the IR detector head, with flexible tubing of 4 m length, 35 ltr. dewar, trolley with 5 swivel wheels, supply voltage 115/230 V, 50/60 Hz	6.256.4-50.0.00





Spare and wear parts for round samples, diameter of 25.4 mm



Spare and wear parts for round samples, diameter of 12.7 mm



LFA 457 *MicroFlash*<sup>®</sup> sample holders for round samples (diameter of 10.0 mm) and square ones (10 mm x 10 mm)



Spare and wear parts for round and square samples, diameter of 8.0 mm



Spare and wear parts for round and square samples, diameter of 6.0 mm

**LFA 457 *MicroFlash*<sup>®</sup> – Standard Sample Holder Insets (Aluminum Titanate, Al<sub>2</sub>TiO<sub>5</sub>) and Caps (SiC) for Round Samples**

Sample Holders Sample Dimension	Remarks	Order Number
25.4 mm	Sample holder for one large sample incl. cap, made of SiC	6.257.1-80.2.00
12.7 mm	Made of SiC, including cap ( <b>recommended standard sample holder</b> )	6.257.1-80.1.00
10.0 mm	Made of SiC, including cap	6.257.1-80.3.00
8.0 mm	Made of SiC, including cap	6.257.1-80.4.00
6.0 mm	Made of SiC, including cap	6.257.1-80.5.00

**LFA 457 *MicroFlash*<sup>®</sup> – Standard Sample Holder Insets (Aluminum Titanate, Al<sub>2</sub>TiO<sub>5</sub>) and Caps (SiC) for Square Samples**

Sample Holders Sample Dimension	Remarks	Order Number
10 mm x 10 mm	Made of SiC, including cap	6.257.1-81.1.00
8 mm x 8 mm	Made of SiC, including cap	6.257.1-81.2.00
6 mm x 6 mm	Made of SiC, including cap	6.257.1-81.3.00

**LFA 457 *MicroFlash*<sup>®</sup> – Spare & Wear Parts of the Standard Sample Holders for Round and Square Samples**

Sample Holders Sample Dimension	Material Inset/Cap	Order Number Sample Inset	Order Number Cap
25.4 mm	Al <sub>2</sub> TiO <sub>5</sub> /SiC	NGB808221	NGB803740
12.7 mm	Al <sub>2</sub> TiO <sub>5</sub> /SiC	NGB806935	NGB803737
10.0 mm	Al <sub>2</sub> TiO <sub>5</sub> /SiC	NGB808224	NGB803779
10.0 mm x 10.0 mm	Al <sub>2</sub> TiO <sub>5</sub> /SiC	NGB808223	NGB803779
8.0 mm	Al <sub>2</sub> TiO <sub>5</sub> /SiC	NGB808222	NGB804623
8.0 mm x 8.0 mm	Al <sub>2</sub> TiO <sub>5</sub> /SiC	NGB808226	NGB804623
6.0 mm	Al <sub>2</sub> TiO <sub>5</sub> /SiC	NGB808225	NGB803809
6.0 mm x 6.0 mm	Al <sub>2</sub> TiO <sub>5</sub> /SiC	NGB812553	NGB803809

**LFA 457 *MicroFlash*<sup>®</sup> – Spare and Wear Parts, Spray**

Part	Material/Content	Order Number
Sealing washer for unused sample holder positions	SiC	NGB803807

LFA 457 *MicroFlash*® – Sample Holders for Special Applications: Liquids

Special Sample Holders	Remarks	Order Number
Sample holder for liquids ("Waxes")	Specifically for easy preparation of wax samples; made of Al 99.9 with lid; for sample holder with a diameter of 12.7 mm, requires base plate NGB803741 and sample holder NGB806935; RT ... 300°C,	6.256.4-91.6.00
Sample container for measurements on non-metallic melts <sup>1</sup> ("Platinum")	Made of Pt/Rh (90/10), for liquids and polymer melts at higher temperatures. The container fits into sample holders with a diameter of 12.7 mm; requires base plate NGB803741 and sample support NGB806935	6.256.4-91.5.00
Sample holder for low-viscosity liquids ("PEEK")	For water, oils and fluid resins; can be used up to approx. 250°C; consisting of reusable stainless steel frames and 5 sets of disposable parts; replaceable. Sample dimensions of a diameter of 15 x 1.5 mm. Sample application by means of cannula via borehole, diameter 1 mm; requires base plate NGB803735 and sample inset NGB808221.	6.256.4-92.7.00
Sample holder for liquid metals ("Sapphire-C")	Sample support and threaded cap nut <b>made of graphite</b> , sample pan and lid made of sapphire. Especially for liquid metallic samples, diameter of 11 mm x 1.5 mm; requires base plate NGB803735 and NGB808221; for temperatures above 300°C, an inert atmosphere is required. An infrared sensor (InSb) is required; order no. 6.256.4-46.0.00. Not applicable in connection with MCT sensor.	6.256.1-93.2.00
Spare and wear parts of "Sapphire-C", order no. 6.256.1-93.2.00	Graphite centering cone Graphite cap Sapphire sample pan Sapphire lid	GB396989 GB396988 GB396990 GB396991
Sample holder for liquid metals and powdery samples ("Sapphire-S")	Sample support and threaded cap <b>made of stainless steel</b> , with sample pan and lid from sapphire, for liquid metallic and powdery samples, diameter of 11 mm x 1.5 mm; requires base plate NGB803735 and sample inset NGB808221	6.256.4-92.9.00
Spare Parts for the sample holder ("Sapphire")	Sapphire sample pan Sapphire lid	GB396990 GB396991

<sup>1</sup> Please note reactions between the container material and the SiC sample holder may occur above 900°C. For measurements above 900°C, we recommend sample holders made of Al<sub>2</sub>O<sub>3</sub> or Al<sub>2</sub>TiO<sub>5</sub>.

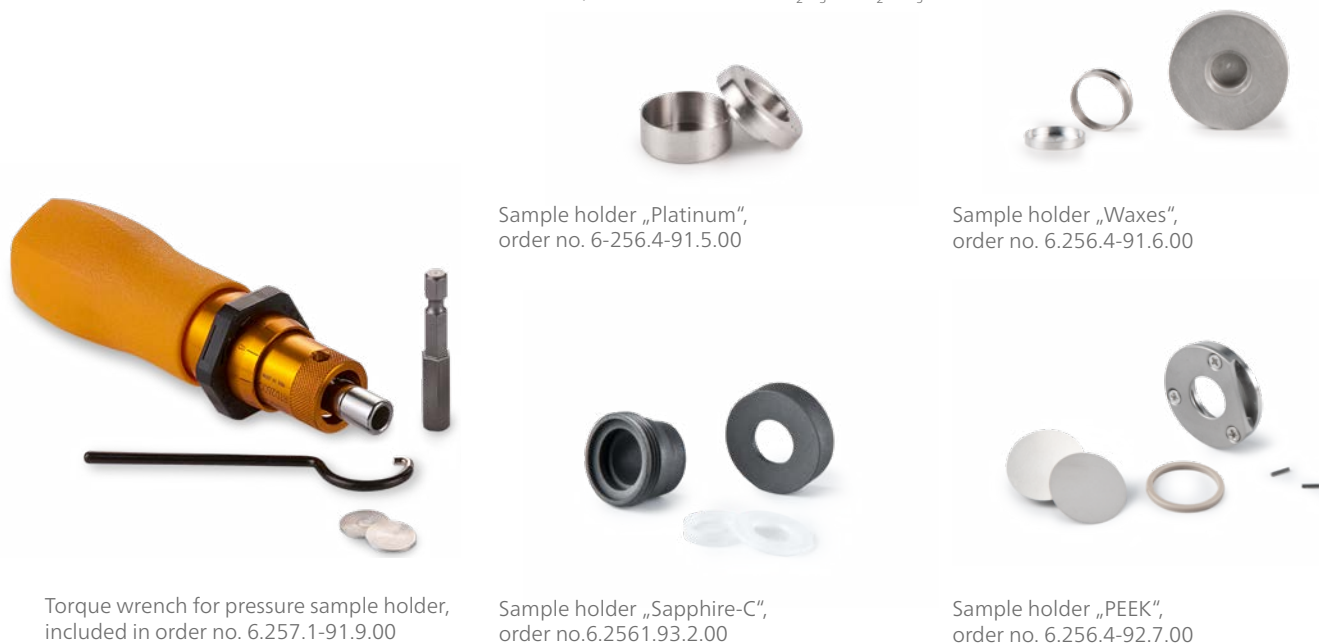

Sample holder „Platinum“, order no. 6-256.4-91.5.00

Sample holder „Waxes“, order no. 6.256.4-91.6.00

Torque wrench for pressure sample holder, included in order no. 6.257.1-91.9.00

Sample holder „Sapphire-C“, order no.6.2561.93.2.00

Sample holder „PEEK“, order no. 6.256.4-92.7.00

LFA 457 MicroFlash® – Sample Holders for Special Applications:  
Fibers, Lamellas, Shrinking/Crumbling Samples, Pressure, In-Plane

Special Sample Holders	Remarks	Order Number
Sample holder for fibrous samples	Made of SiC/Al <sub>2</sub> O <sub>3</sub> , consisting of base part (SiC), cap (SiC) and 3 sets of fiber holder rings (Al <sub>2</sub> O <sub>3</sub> ). Please note: Sample preparation requires tool set 6.256.1-93.4.00; requires base plate NGB803741	6.257.1-93.1.00
Tool set	For sample holder for fibrous samples 6.257.1-93.1.00	6.256.1-93.4.00
Spare and wear parts of sample holder for fibrous samples (6.257.1-93.1.00)	FSiC sample support SiC cap Shells and fixing ring made of Al <sub>2</sub> O <sub>3</sub>	NGB803742 NGB803743 6.256.1-93.3.00
Sample holder for in-plane measurements	Made of stainless steel, set for in-plane test on highly conductive samples, consisting of sample holder inset and cap; sample dimensions of a diameter of 20 ... 25.4 mm, thickness of max. 1 mm; <b>requires base plate NGB803735 and NGB808221</b>	6.257.1-91.2.00
Sample holder for lamellar samples	Sample support and cap made of graphite to accommodate lamellar samples. The individual lamellas are compressed to a total sample size of 10 x 10 mm <sup>2</sup> with clamping screws (graphite). Above 300°C, an inert atmosphere is required; requires base plate NGB803741.	6.257.1-90.8.00
Spare and wear parts of sample holder for lamellar samples (6.257.1-90.8.00)	Graphite sample support Graphite cap Graphite pressure screw	GB800201 NGB803810 GB800200
Pressure sample holder	Pressure-calibrated sample holder; pressure up to 5 MPa; 3-layer analysis; including torque wrench for 60 ...260 Ncm; maximum working temperature of 300°C; requires base plate NGB803735 and NGB808221	6.257.1-91.9.00
Component parts for pressure sample holder	Disk made of aluminum, for standard applications	6.257.1-91.1.03
	Disk made of sapphire	NGB812117
Sample holder for samples which shrink or crumble upon heating	Wire mesh made of tungsten, mesh width 2.75 mm, for sample holder made of Al <sub>2</sub> O <sub>3</sub> , diam. 12.7 mm; <b>requires base plate NGB803741 and sample support NGB806935</b>	NGB812130
Sample holder for samples which shrink or crumble upon heating	Grid made of Pt30%Rh, wire diam. 0.5 mm, mesh width 4 mm, for sample support made of SiC, diam. 12.7 mm, <b>requires base plate NGB803741 and sample support NGB806935</b> ; maximum working temperature of 900°C	6.257.1-94.4.01
Sample holder for samples which shrink or crumble upon heating	Grid made of Pt30%Rh, wire diam. 0.5 mm, mesh width 2.75 mm, for sample support made of Al <sub>2</sub> O <sub>3</sub> , diam. 12.7 mm; <b>requires base plate NGB803741 and sample support NGB806935</b>	6.257.1-94.4.02



Sample holder for in-plane tests,  
order no. 6.257.1-91.2.00

Sample holder for fibrous samples,  
order no. 6.257.1-93.1.00

Sample holder for lamellar samples,  
order no. 6.257.1-90.8.00

# LFA 427

## LFA 427 – Sample Holders and Accessories

The LFA 427 is the most versatile LFA system, for R&D as well as for any application involving the characterization of standard or high-performance materials in fields such as automobile manufacturing, aeronautics, astronautics and energy technology.

The following tables are intended to provide an overview of all available sample holders, centering cones, caps and special sample holders for special applications.



LFA 427

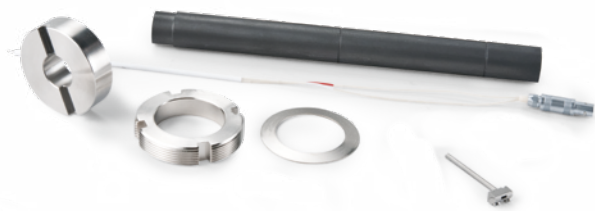

Graphite sample holder set, order no. 6.256.1-90.3.00 and 6.256.6-90.3.00; sample holder will be delivered preassembled.



Graphite/stainless steel sample holder set, order no. 6.256.3-22.0.00 and 6.256.6-22.0.00; sample holder will be delivered preassembled.

### LFA 427 – Sample Holder Sets\* for the different furnace types

Furnace Type	Sample Holder	Centering Cone/ Sample Diameter	Cover	Thermocouple Type/ Pyrometer	Order Number
2800°C	Graphite, for pyrometrical measurements RT... 2800°C <sup>1</sup>	Graphite, ø 12.7 mm	Graphite	Pyrometer (> 300°C inert atmosphere required)	6.256.6-24.0.00
	Graphite, for measurements between RT ... 2000°C <sup>1</sup>	Graphite, ø 12.7 mm	Graphite	W3%Re-W25%Re (> 300°C inert atmosphere required)	6.256.6-26.0.00

LFA 427 – Sample Holder Sets\* for the different furnace types

Furnace Type	Sample Holder	Centering Cone/ Sample Diameter	Cover	Thermocouple Type/ Pyrometer	Order Number
2000°C	Graphite	Graphite, ø 12.7 mm	Graphite	W3%Re-W25%Re (> 300°C inert atmosphere required)	6.256.6-90.3.00
	Graphite	Graphite, ø 12.7 mm	Graphite	W3%Re-W25%Re (> 300°C inert atmosphere required)	6.256.1-90.3.00
	Graphite**	Graphite, ø 20.0 mm	Graphite	W3%Re-W25%Re (> 300°C inert atmosphere required)	6.256.6-21.0.00
	Graphite**	Graphite, ø 20.0 mm	Graphite	W3%Re-W25%Re (> 300°C inert atmosphere required)	6.256.4-21.0.00
	Al <sub>2</sub> O <sub>3</sub> /SSiC	Al <sub>2</sub> O <sub>3</sub> , ø 12.7 mm	SSiC	S; max. 1700°C	6.256.6-90.1.00
	Al <sub>2</sub> O <sub>3</sub> /SSiC	Al <sub>2</sub> O <sub>3</sub> , ø 12.7 mm	SSiC	S; max. 1700°C	6.256.4-90.1.00
	Al <sub>2</sub> O <sub>3</sub> /SSiC*	Al <sub>2</sub> O <sub>3</sub> , ø 20.0. mm	SSiC	S; max. 1700°C	6.256.6-20.0.00
	Al <sub>2</sub> O <sub>3</sub> /SSiC*	Al <sub>2</sub> O <sub>3</sub> , ø 20.0. mm	SSiC	S; max. 1700°C	6.256.4-20.0.00
1575°C and 1300°C	Al <sub>2</sub> O <sub>3</sub> /SSiC	Al <sub>2</sub> O <sub>3</sub> , ø 12.7 mm	SSiC	S	6.256.6-90.1.00
	Al <sub>2</sub> O <sub>3</sub> /SSiC	Al <sub>2</sub> O <sub>3</sub> , ø 12.7 mm	SSiC	S	6.256.4-90.1.00
	Al <sub>2</sub> O <sub>3</sub> /SSiC*	Al <sub>2</sub> O <sub>3</sub> , ø 20.0. mm	SSiC	S	6.256.6-20.0.00
	Al <sub>2</sub> O <sub>3</sub> /SSiC*	Al <sub>2</sub> O <sub>3</sub> , ø 20.0. mm	SSiC	S	6.256.4-20.0.00
	Graphite	Graphite, ø 12.7 mm	Graphite	W3%Re-W25%Re (> 300°C inert atmosphere required)	6.256.6-90.3.00
	Graphite	Graphite, ø 12.7 mm	Graphite	W3%Re-W25%Re (> 300°C inert atmosphere required)	6.256.4-90.3.00
	Graphite**	Graphite, ø 20.0 mm	Graphite	W3%Re-W25%Re (> 300°C inert atmosphere required)	6.256.6-21.0.00
	Graphite**	Graphite, ø 20.0 mm	Graphite	W3%Re-W25%Re (> 300°C inert atmosphere required)	6.256.4-21.0.00
-120°C to 400°C	Graphite/ stainless steel	Graphite, ø 12.7 mm	Graphite	E (> 300°C inert atmosphere required); max. 400°C	6.256.6-22.0.00
	Graphite/ stainless steel	Graphite, ø 12.7 mm	Graphite	E (> 300°C inert atmosphere required); max. 400°C	6.256.3-22.0.00
	Al <sub>2</sub> O <sub>3</sub> /SSiC/ stainless steel	Al <sub>2</sub> O <sub>3</sub> , ø 12.7 mm	SSiC	E (> 300°C inert atmosphere required); max. 400°C	6.256.6-23.0.00
	Al <sub>2</sub> O <sub>3</sub> /SSiC/ stainless steel	Al <sub>2</sub> O <sub>3</sub> , ø 12.7 mm	SSiC	E (> 300°C inert atmosphere required); max. 400°C	6.256.3-23.0.00

\* Order no. is related to instrument number; e.g., order no. 6.256.6-xxx is available for LFA 427 systems 6.256.6-11.0.00; order no. 6.256.1-xxx and 6.256.4-xxx is available for LFA systems 6.256.4-11.00 and 6.256.3-xxx.

\*\* Measuring part with 20-mm laser system required.

1 only for use with furnace 6.256-08.0.00

LFA 427 – Spare Parts\* for Sample Holders (Carrier Tubes and Sample Thermocouples)

Sample Holder in Use (Furnace, Sample Holder Type)	Carrier Tube with Flange	Order Number Carrier Tube	Sample Thermocouple	Order Number
6.256.6-90.3.00 (2000°C, graphite)	Graphite	6.256.1-21.1.00	W3%Re-W25%Re, with two-hole capillary tube and thermocouple connectors, WRe fixing wire included	6.256.6-21.1.00
6.256.1-90.3.00 (2000°C, graphite)	Graphite	6.256.1-21.1.00	W3%Re-W25%Re, with two-hole capillary tube and thermocouple connectors, WRe fixing wire included	6.256.1-21.2.00
6.256.6-90.1.00 (1575°C/1300°C, Al <sub>2</sub> O <sub>3</sub> /SSiC)	Al <sub>2</sub> O <sub>3</sub>	6.256.1-20.1.00	Type S, wire ø 0.5 mm, with twohole capillary tube and thermocouple connectors, Pt fixing wire	6.256.6-20.1.00
6.256.4-90.1.00 (1575°C/1300°C, Al <sub>2</sub> O <sub>3</sub> /SSiC)	Al <sub>2</sub> O <sub>3</sub>	6.256.1-20.1.00	Type S, wire ø 0.5 mm, with twohole capillary tube and thermocouple connectors, Pt fixing wire	6.256.1-20.7.00
6.256.1-90.1.00 (1575°C/1300°C, Al <sub>2</sub> O <sub>3</sub> /SSiC)	Al <sub>2</sub> O <sub>3</sub>	6.256.1-20.1.00	Type S, wire ø 0.3 mm, with twohole capillary tube and thermocouple connectors, Pt fixing wire	6.256.1-20.2.00
6.256.6-22.0.00 (400°C, graphite/ stainless steel)	Graphite/stain	6-256.3-22.1.00	Type E, wire ø 0.32 mm, with twohole capillary tube and thermocouple connectors, fixing wire	6.256.6-22.1.00
6.256.3-22.0.00 (400°C, graphite/ stainless steel)	Graphite/stain	6-256.3-22.1.00	Type E, wire ø 0.32 mm, with twohole capillary tube and thermocouple connectors, fixing wire	6.256.6-22.2.00
6.256.6-23.0.00 (400°C, Al <sub>2</sub> O <sub>3</sub> /SSiC/ stainless steel)	Al <sub>2</sub> O <sub>3</sub> / stainless steel	6.256.3-23.1.00	Type E, wire ø 0.32 mm, with twohole capillary tube and thermocouple connectors, fixing wire	6.256.6-22.1.00
6.256.3-23.0.00 (400°C, Al <sub>2</sub> O <sub>3</sub> /SSiC/ stainless steel)	Al <sub>2</sub> O <sub>3</sub> / stainless steel	6.256.3-23.1.00	Type E, wire ø 0.32 mm, with twohole capillary tube and thermocouple connectors, fixing wire	6.256.6-22.2.00
6.256.6-26.0.00 (2800°C, graphite)	Graphite	6.256.6-26.1.00	W3%Re-W25%Re, with two-hole capillary tube and thermocouple connectors, WRe fixing wire included	6.256.6-26.2.00
6.256.6-24.0.00 (2800°C, graphite)	Graphite	6.256.6-24.1.00		
6.256.6-21.0.00 (2000°C, graphite)	Graphite for sample holder ø 20 mm	6.256.4-21.1.00	W3%Re-W25%Re, with two-hole capillary tube and thermocouple connectors, WRe fixing wire included	6.256.6-21.1.00
6.256.4-21.0.00 (2000°C, graphite)	Graphite for sample holder ø 20 mm	6.256.4-21.1.00	W3%Re-W25%Re, with two-hole capillary tube and thermocouple connectors, WRe fixing wire included	6.256.1-21.1.00
6.256.6-20.0.00 (2000°C, graphite)	Al <sub>2</sub> O <sub>3</sub> for sample holder ø 20 mm	6.256.4-20.1.00	Type S, wire ø 0.5 mm, with twohole capillary tube and thermocouple connectors, Pt fixing wire	6.256.6-20.1.00
6.256.4-20.0.00 (2000°C, graphite)	Al <sub>2</sub> O <sub>3</sub> for sample holder ø 20 mm	6.256.4-20.1.00	Type S, wire ø 0.5 mm, with twohole capillary tube and thermocouple connectors, Pt fixing wire	6.256.1-20.7.00

\* Order no. is related to instrument number; e.g., order no. 6.256.6-xxx is available for LFA 427 systems 6.256.6-11.0.00; order no. 6.256.4-xxx is available for LFA systems 6.256.4-11.0.00, etc.





Centering cones and caps for sample of 6 mm diameter; centering cones made of Al<sub>2</sub>O<sub>3</sub> (white) and graphite (grey); caps made of SSiC (left) and graphite (right).



Centering cones and caps for sample of 12.7 mm; centering cones made of Al<sub>2</sub>O<sub>3</sub> (white) and graphite (grey); caps made of SSiC (left) and graphite (right).



Centering cones and caps for round and square samples (diam. of 10 mm); centering cones made of Al<sub>2</sub>O<sub>3</sub> (white) and graphite (grey); caps made of SSiC and graphite.

**LFA 427 – Sample Supports Made of Al<sub>2</sub>O<sub>3</sub> Centering Cone/SSiC Cap for Sample Holders**  
 6.256.6-90.1.00, 6.256.4-90.1.00, 6.256.3-90.1.00, 6.256.1-90.1.00, 6.256.6-23.0.00,  
 6.256.3-23.0.00 (1575°C furnace and 400°C furnace)

Sample Diameter	Order Number Centering Cone & Cap	Order Number Single Centering Cone	Order Number Single Cap
12.7 mm	6.256.1-91.6.00	GB396535	SSiC: GB396653 Al <sub>2</sub> O <sub>3</sub> : GB396537*
10.0 mm	6.256.1-92.6.00	NGB802392	SiC: GB802393 Al <sub>2</sub> O <sub>3</sub> : NGB812372*
10.0 mm x 10.0 mm	6.256.1-92.9.00	NGB803573	GB802393
8.0 mm	6.256.1-93.8.00	NGB810752	(SiC) NGB810760
6.0 mm	6.256.1-91.7.00	GB396536	GB396652

\* Graphite coating required

**LFA 427 – Sample Supports Made of Al<sub>2</sub>O<sub>3</sub> Centering Cone/SSiC Cap for Sample Holders** 6.256.6-20.0.00 and  
 6.256.4-20.0.00 (1575°C furnace and 1300°C furnace)

Sample Diameter	Order Number Centering Cone & Cap	Order Number Single Centering Cone	Order Number Single Cap
20.0 mm	6.256.4-20.2.00	NGB805022	NGB805021

**LFA 427 – Sample Supports Made of Graphite (Centering Cones and Caps) for Sample Holders 6.256.6-24.0.00 (Highest Temperature Furnace)**

Sample Diameter	Order Number Centering Cone & Cap	Order Number Single Centering Cone	Order Number Single Cap
12.7 mm	6.256.4-21.3.00	NGB810531	NGB810532
10.0 mm	6.256.4-21.4.00	NGB812143	NGB812144
10.0 mm x 10.0 mm	6.256.4-21.5.00	NGB812145	NGB812144
6.0 mm	6.256.4-21.6.00	NGB812146	NGB812147

**LFA 427 – Sample Supports Made of Graphite\* (Centering Cones and Caps) for Sample Holders 6.256.6-90.3.00, 6.256.1-90.3.00, 6.256.6-22.0.00, 6.256.3-22.0.00, 6.256.6-26.0.00 (Furnaces 400°C ... 2000°C)**

Sample Diameter	Order Number Centering Cone & Cap	Order Number Single Centering Cone	Order Number Single Cap
12.7 mm	6.256.1-91.1.00	GB396544	GB396545
10.0 mm	6.256.1-92.8.00	NGB802558	NGB811013
10.0 mm x 10.0 mm	6.256.1-91.8.00	GB396992	GB802393
6.0 mm	6.256.1-91.2.00	GB396855	GB396854

\* Using sample holders made of graphite requires thermocouple W3%Re-W25%Re, order no. 6.256.1-21.1.00 or 6.256.6-21.1.00

**LFA 427 – Sample Supports Made of Graphite\* for Sample Holders 6.256.6-21.0.00 and 6.256.4-21.0.00 (Furnaces 1575°C and 1300°C)**

Sample Diameter	Order Number Centering Cone & Cap	Order Number Single Centering Cone	Order Number Single Cap
20.0 mm	6.256.4-21.2.00	NGB810529	NGB810530
12.7 mm	6.256.4-21.3.00	NGB810531	NGB810532
10.0 mm	6.256.4-21.4.00	NGB812143	NGB812144
10.0 mm x 10.0 mm	6.256.4-21.5.00	NGB812145	NGB812144
6.0 mm	6.256.4-21.6.00	NGB812146	NGB812147

\* Using sample holders made of graphite requires thermocouple W3%Re-W25%Re, order no. 6.256.1-21.1.00 or 6.256.6-21.1.00



Sample support and cap made of graphite

LFA 427 sample holder for in-plane tests, order no. 6.257.1-91.2.00



LFA 427 – Sample Holders for Special Applications: Fibers, Shrinking/Crumbling Samples, Pressure, In-Plane for Sample Holders 6.256.6-90.1.00, 6.256.4-90.1.00, 6.256.1-90.1.00, 6.256.6-23.0.00, 6.256.3-23.0.00 (Furnaces: 1575°C, 1300°C, 400°C Furnace)

Special Sample Holders	Remarks	Order Number
Sample holder for fibrous samples	Made of Al <sub>2</sub> O <sub>3</sub> , consisting of two half-shells and fixing ring. Please note: Sample preparation requires tool set 6.256.1-93.4.00	6.256.1-93.3.00
Sample holder for fibrous samples	Made of graphite, consisting of two half-shells and fixing ring. Please note: Sample preparation requires tool set 6.256.1-93.4.00	6.256.1-93.6.00
Tool set	For sample holder for fibrous samples 6.257.1-93.1.00	6.256.1-93.4.00
Sample holder for in-plane measurements	Made of stainless steel, set for in-plane test on highly conductive samples, consisting of sample holder inset and cap; sample dimensions of diam. 20 ... 25.4 mm, thickness of max. 1 mm	6.257.1-91.2.00
Pressure sample holder	Pressure-calibrated sample holder; pressure up to 5 MPa; 3-layer analysis; including torque wrench for 60 ...260 Ncm; maximum working temperature of 300°C	6.256.4-92.8.00
Disk made of Al	For pressure sample holder 6.256.6-92.8.00	6.257.1-91.1.03
Disk made of sapphire	For pressure sample holder 6.256-92.8.00	NGB812117
Sample holder for samples which shrink or crumble upon heating	Wire mesh made of tungsten, mesh width 4 mm, for sample holder made of SiC, ø 12.7 mm order no. NGB803738	NGB812129
Sample holder for samples which shrink or crumble upon heating	Wire mesh made of tungsten, mesh width 2.75 mm, for sample holder made of Al <sub>2</sub> O <sub>3</sub> , ø 12.7 mm	NGB812130
Sample holder for samples which shrink or crumble upon heating	Grid made of Pt30%Rh, ø 0.5 mm, mesh width 4 mm, for sample support made of SiC, ø 12.7 mm, order no. NGB803738; maximum working temperature of 900°C	6.257.1-94.4.01
Sample holder for samples which shrink or crumble upon heating	Grid made of Pt30%Rh, ø 0.5mm, mesh width 2.75 mm, for sample support made of Al <sub>2</sub> O <sub>3</sub> , ø 12.7 mm	6.257.1-94.4.02



Sample holder for fibrous samples made of graphite, order no. 6.256.1-93.6.00, but also available in Al<sub>2</sub>O<sub>3</sub>, order no. 6.256.1-93.3.00.



Torque wrench included in pressure sample holder set, order no. 6.256.4-92.8.00

**LFA 427 – Sample Holders for Special Applications: Liquids for Sample Holders 6.256.6-90.1.00, 6.256.4-90.1.00, 6.256.1-90.1.00, 6.256.6-23.0.00, 6.256.3-23.0.00 (Furnaces: 1575°C, 1300°C, 400°C Furnace)**

Special Sample Holders	Remarks	Order Number
Sample container for liquids ("Waxes")	Specifically for easy preparation of wax samples, made of Aluminum (99.9)/stainless steel, for tests around room temperature to 300°C. The container fits into sample holders with a diameter of 12.7 mm.	6.256.4-91.6.00
Sample container for measurements on liquids ("Slags")	Sample container for testing samples in the liquid state. Sample pan and lid made of PtRh 90/10, centering ring made of Al <sub>2</sub> O <sub>3</sub> , guiding sleeve made of Al <sub>2</sub> O <sub>3</sub> .	6.256.1-93.5.00
Sample container for measurements on non-metallic melts <sup>1)</sup> ("Platinum")	Made of Pt/Rh (90/10), for liquids and polymer melts at higher temperatures. The container fits into sample holders with a diameter of 12.7 mm.	6.256.4-91.5.00
Sample holder for liquid metals and powdery samples ("Sapphire-S")	Sample support and threaded cap made of stainless steel, sample pan and lid made of sapphire, for measurements up to 500°C. Especially for liquid metallic and powdery samples, diameter of 11 mm x 1.5 mm.	6.256.4-92.9.00

1) Please note that reactions between the container and the SiC sample holder may occur above 900°C. For measurements above 900°C, we recommend sample holders made of Al<sub>2</sub>O<sub>3</sub> or Al<sub>2</sub>TiO<sub>5</sub>.

**LFA 427 – Sample Holders for Special Applications: Fibers, Lamellas, Pressure, In-Plane for Sample Holders 6.256.6-90.3.00, 6.256.1-90.3.00, 6.256.6-22.0.00, 6.256.3-22.0.00, 6.256.6-26.0.00 (Furnaces 400°C ... 2000°C)**

Special Sample Holders/ Containers	Remarks	Order Number
Sample holder for fibrous samples	Made of graphite, consisting of two half-shells and fixing ring. Please note: Sample preparation requires tool set 6.256.1-93.4.00	6.256.1-93.6.00
Tool set	For sample holder for fibrous samples 6.257.1-93.1.00	6.256.1-93.4.00
Sample holder for lamellar samples	Sample support and cap made of graphite. The single lamellas are compressed to a total size of 10 mm x 10 mm by using clamping screws made of graphite. Above 300°C, an inert atmosphere is required.	6.256.1-91.9.00
Sample holder for in-plane measurements	Made of stainless steel, set for in-plane test on highly conductive samples, consisting of sample holder inset and cap; sample dimensions of diam. 20 ... 25.4 mm, thickness of max. 1 mm. A reference sample made of graphite (diameter of 25.4 mm x 0.6 mm, order no. NIB007657) is available but not necessarily required.	6.257.1-91.2.00
Pressure sample holder	Pressure-calibrated sample holder; pressure up to 15 MPa; 3-layer analysis; including torque wrench for 60 ...260 Ncm; maximum working temperature 300°C	6.256.4-92.8.00
Disk made of Al	For pressure sample holder 6.256.6-92.8.00	6.257.1-91.1.03
Disk made of sapphire	For pressure sample holder 6.256-92.8.00	NGB812117



Sample container „Waxes“, order no. 6.256.4-91.6.00

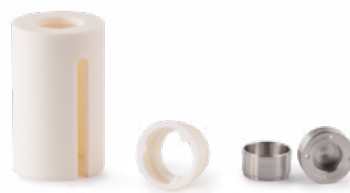

Sample container „Slags“, order no. 6.256.1-93.5.00



Sample holder "Platinum", order no. 6.256.4-91.5

**LFA 427 – Sample Holders for Special Applications: Liquids for Sample Holders 6.256.6-90.3.00, 6.256.1-90.3.00, 6.256.6-22.0.00, 6.256.3-22.0.00, 6.256.6-26.0.00 (Furnaces 400°C ... 2000°C)**

Special Sample Holders/ Containers	Remarks	Order Number
Sample container for liquids ("Waxes")	Specifically for easy preparation of wax samples, made of aluminum (99.9)/stainless steel, for tests around room temperature to 300°C. The container fits into sample holders with diameter of 12.7 mm.	6.256.4-91.6.00
Sample container for measurements on non-metallic melts <sup>1)</sup> ("Platinum")	Made of Pt/Rh (90/10), for liquids and polymer melts at higher temperatures. The container fits into sample holders with a diameter of 12.7 mm.	6.256.4-91.5.00
Sample holder for liquid metals and powdery samples ("Sapphire-S")	Sample support and threaded cap made of stainless steel, sample pan and lid made of sapphire, for measurements up to 500°C. Especially for liquid metallic and powdery samples, diameter of 11 mm x 1.5 mm.	6.256.4-92.9.00
Spare Parts for the sample holder ("Sapphire")	Sapphire sample pan Sapphire lid	GB396990 GB396991
Sample holder for liquid metals ("Sapphire-C")	Sample support and threaded cap made of graphite, sample pan and lid made of sapphire. Especially for liquid metallic samples, diameter of 11 mm x 1.5 mm. Above 300°C, an inert atmosphere is required.	6.256.1-93.2.00
<ul style="list-style-type: none"> <li>▪ Centering cone</li> <li>▪ Cap</li> <li>▪ Sample crucible</li> <li>▪ Lid</li> </ul>	<ul style="list-style-type: none"> <li>Made of graphite</li> <li>Made of graphite</li> <li>Made of sapphire</li> <li>Made of sapphire</li> </ul>	<ul style="list-style-type: none"> <li>GB396989</li> <li>GB396988</li> <li>GB396990</li> <li>GB396991</li> </ul>

1) Please note that reactions between the container and the SiC sample holder may occur above 900°C. For measurements above 900°C, we recommend sample holders made of Al<sub>2</sub>O<sub>3</sub> or Al<sub>2</sub>TiO<sub>5</sub>.

**LFA 427 – LN<sub>2</sub>-Refilling System for the Infrared Detector Head**

Device	Remarks	Order Number
LN <sub>2</sub> -Refilling System	LN <sub>2</sub> -Refilling system for the Infrared detector head, with flexible LN <sub>2</sub> -tubing, length 4 m, 35 ltr. Al dewar, trolley with 5 swivel wheels, supply voltage 115/230 V, 50/60 Hz	6.256.4-50.0.00



Pressure sample holder with torque wrench, order no. 6.256.4-92.8.00



Sample holder "Sapphire-C", order no. 6.256.1-93.2.00

# Applications

## Sample Holder for Low-Viscosity Liquids ("PEEK")

For LFA measurements, a defined sample thickness is required. The thermal diffusivity ( $a$ ) is proportional to the square of the sample thickness ( $d$ ):  $a \sim d^2$ . This means that high precision is necessary in order to obtain the exact thickness value, especially for thin samples or films of less than 600  $\mu\text{m}$  in thickness.

The heat flow through the outer container walls in axial direction can also be critical for sample holders for liquids, pastes and powders.

Furthermore, measurements on polymer melts and resins during curing can destroy the entire sample holder if the walls on the crucible and aluminum lid are too thin.

In order to handle the critical issues mentioned, a sample holder for low-viscosity liquids such as water, oils and resins (e.g., during curing) is available (order no. 6.256.4-92.7.00).

The special design – with parts made of stainless steel and a PEEK ring – allows for high-precision measurements in less time at a reduced cost.

The sample holder consists of two metal plates with orifices, separated by a PEEK ring of a well-defined thickness. Between each of the orifice plates and the central distancing ring, a thin solid sheet metal plate is inserted.

This sample holder setup creates a tight volume with well-defined internal dimensions.

The liquid sample is measured within the polymer (PEEK) ring, between the two stainless steel plates. The parts are fixated between the two metal plates with orifices: a carrier ring and a cover plate made of stainless steel. A filling port in the PEEK ring allows for injection of the liquid after all of the parts have been assembled.

A second port allows the gas to escape the system during the filling process.

The sample holder can thus also be filled with a highly viscous liquid without risking the formation of a blowhole.

Once the sample holder is completely filled, the two ports are closed. Following the LFA tests, the system can be disassembled and the cured resin disk can be removed for final inspection or for further analysis. The stainless steel plates and the PEEK ring can be easily exchanged.

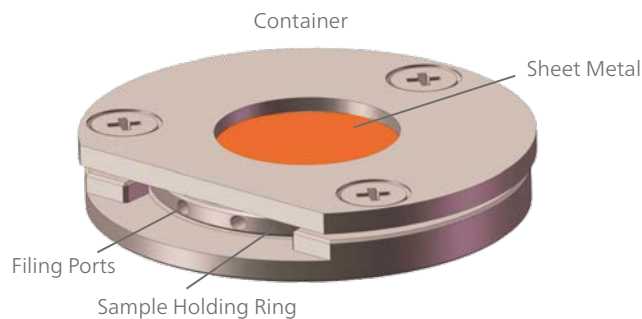

Sample holder for low-viscosity liquids, order no. 6.256.4-92.7.00

## LFA Measurements on Water

In this example, multiple measurements were conducted on water with the sample holder for low-viscosity liquids. The measurement results are in perfect agreement with the values typically found in literature for this liquid. The differences between the individual results, as well as the difference between the average value of these individual results and literature values, vary by less than 2.5% over the entire temperature range. This sample holder is available for all LFA devices.

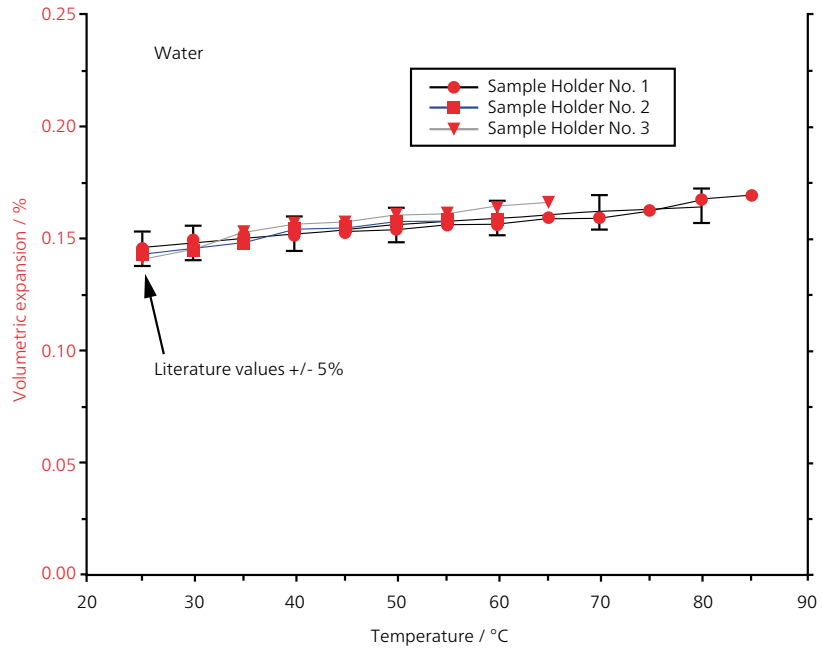

LFA measurements on water between RT and 85°C (sample thickness 1.5 mm).

## An Epoxy Resin During Curing

This plot depicts the results of LFA measurements on an epoxy resin during curing at 60°C, 80°C and 100°C. At each temperature, a series of tests was performed for a period of approximately 110 minutes. This special temperature program was designed to mimic the typical curing process in a production plant.

The tests were carried out by preheating the sample holder setup of the instrument to the selected temperature. The sample was then inserted and the tests were begun immediately. The results clearly show an increase in thermal diffusivity for all three cases. The results at 60°C exhibit a nearly constant increase over time. At 80°C, the thermal diffusivity increases more quickly and is linear for the first 30 minutes, followed by a step in the curve. The most rapid increase in the thermal diffusivity can be observed in the 100°C measurement. Here, the thermal diffusivity has a two-step character.

After 80 minutes, the results of all of the tests arrived at a nearly stable plateau.

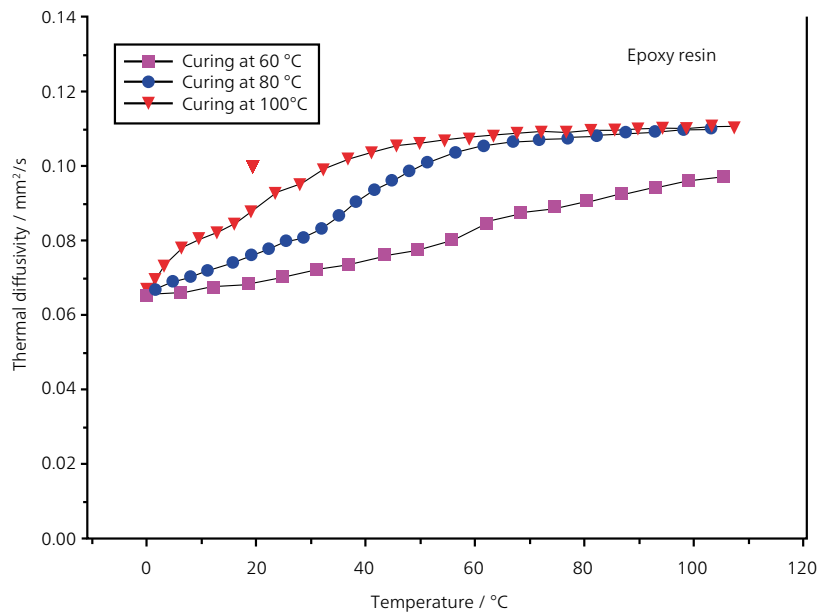

Typical curing process of an epoxy resin in the production plant, simulated by LFA.

## Sample Container for Measurements on Liquids (“Waxes”)

The sample container for measurements on liquids consists of aluminum (99.9) and stainless steel parts. It is specifically designed for easy preparation of wax samples. It is available for the LFA 447 *NanoFlash*®, LFA 467 *HyperFlash*®, LFA 457 *MicroFlash*® and LFA 427.

The sample holder allows for comfortable sample preparation while guaranteeing a defined sample thickness by means of the special design. The container fits into standard sample holders with a diameter of 12.7 mm.



Sample container for liquids made of Al, order no. 6.256.4-91.6.00

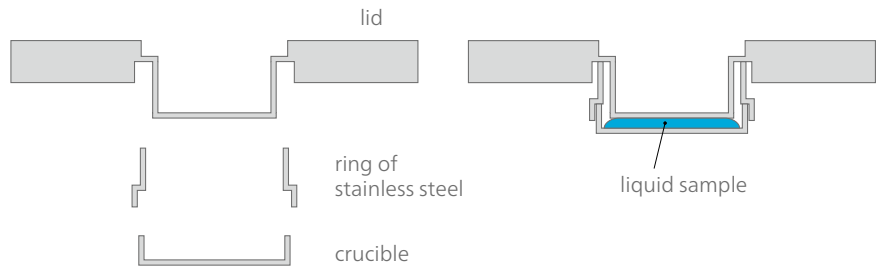

Aluminum sample holder for low-viscosity liquids

## Ethylene Glycol

The primary application of ethylene glycol is as an engine coolant and anti-freeze. Due to its low freezing point, it has also been used as a deicing fluid for windshields and jet engines. This plot shows the results for the thermal diffusivity and thermal conductivity of an ethylene glycol sample. The results are compared with literature values for the thermal conductivity. The uncertainty of the literature values was assumed to be 3% and is depicted as error bars in the figure. It can be seen that the deviations between the literature values and measurement results are well within the uncertainty range for the test method (approximately 5%) and within the uncertainty range for the literature values as well. Thermal conductivity increased with temperature.

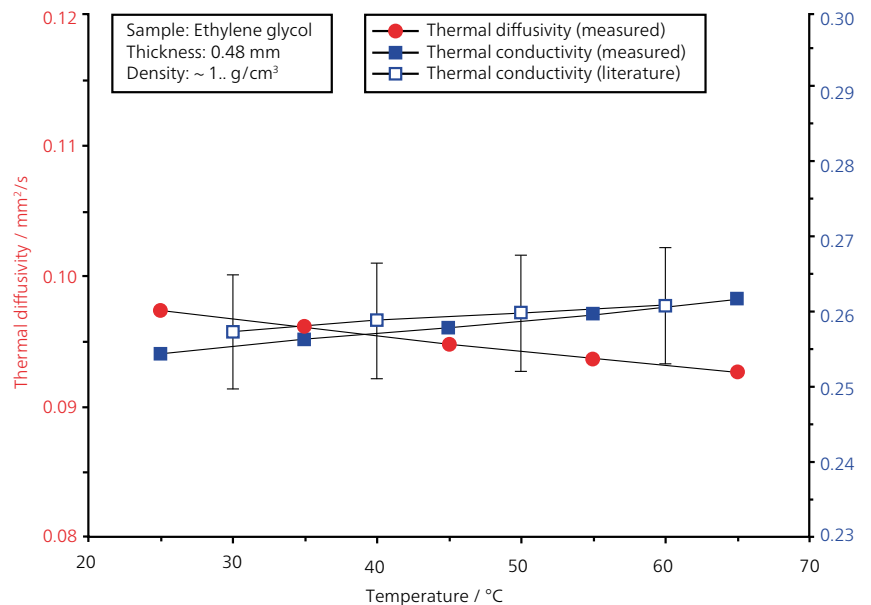

Thermal diffusivity and thermal conductivity of an engine coolant

## Sample Container for Measurements on Liquids and Polymer Melts (“Platinum”)

For measurements on liquids and polymer melts, a sample container made of Pt/Rh has been developed (order no. 6.256.4-91.5.00\*).



This container fits into sample holders with a diameter of 12.7 mm. Measurements on materials such as phase change materials (PCM) can be carried out in the solid and liquid state, as well as in the range where the phase change occurs.

This sample holder is available for the LFA 457 *MicroFlash*<sup>®</sup> and LFA 427.

Sample container, order no. 6.256.4-91.5.00.

\* Please note that reactions between the container and the SiC sample holder may occur above 900°C. For measurements above 900°C, we recommend sample holders made of Al<sub>2</sub>O<sub>3</sub> or Al<sub>2</sub>TiO<sub>5</sub>.

## Paraffin – PCM

The appeal of phase change materials (PCMs) is that they are capable of both latent and sensible heat energy storage, resulting in a greater heat storage capacity per unit of volume than for conventional materials. This plot contains the results of LFA measurements on paraffin from the solid into the liquid state. In the specific heat (DSC 404 *F1 Pegasus*<sup>®</sup> measurement, the melting enthalpy is visible as an overlapping endothermic effect. The specific heat without the heat of fusion was determined by an interpolation process. The thermal diffusivity decreases across the entire temperature range. Above 35°C, the values are nearly constant.

In the melting region, the apparent values measured were corrected for the influence of the ongoing melting process. The correction is based on tests with various well-defined pulse energies at each temperature.

Extrapolating the results to a pulse energy of 0 allows the thermal diffusivity to be calculated without the influence of melting/solidification.

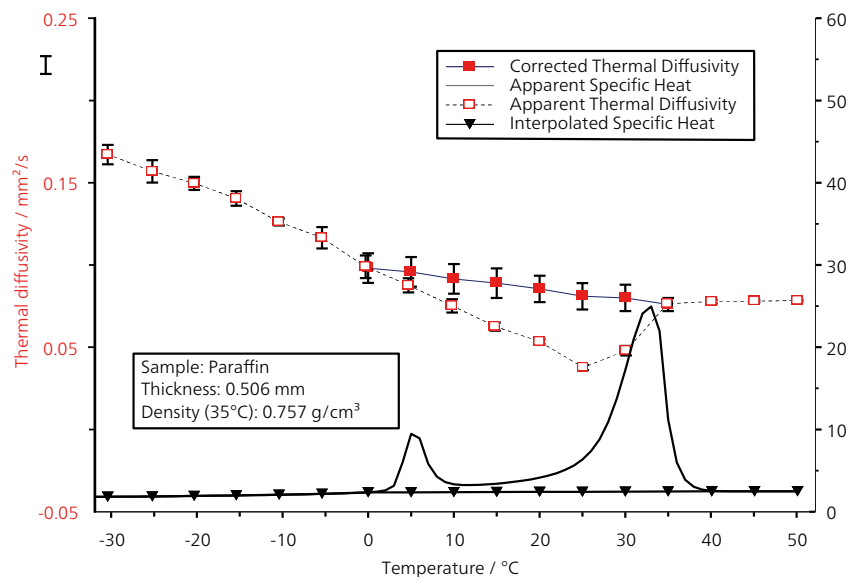

LFA and DSC measurement into the melting range of paraffin



## Sample Holder for Slags

For the temperature range above the softening point of a material such as glass, a special sample holder made of platinum for slags and pastes is available (order no. 6.256.1-93.5.00). This sample holder set consists of a sample pan and lid made of PtRh (90/10), and a centering ring and a guide sleeve both made of  $Al_2O_3$ . This sample holder is available for the LFA 427.



Sample holder for liquid slags (LFA 427), order no. 6.256.1-93.5

## Thermophysical Properties of a CRT Glass Panel

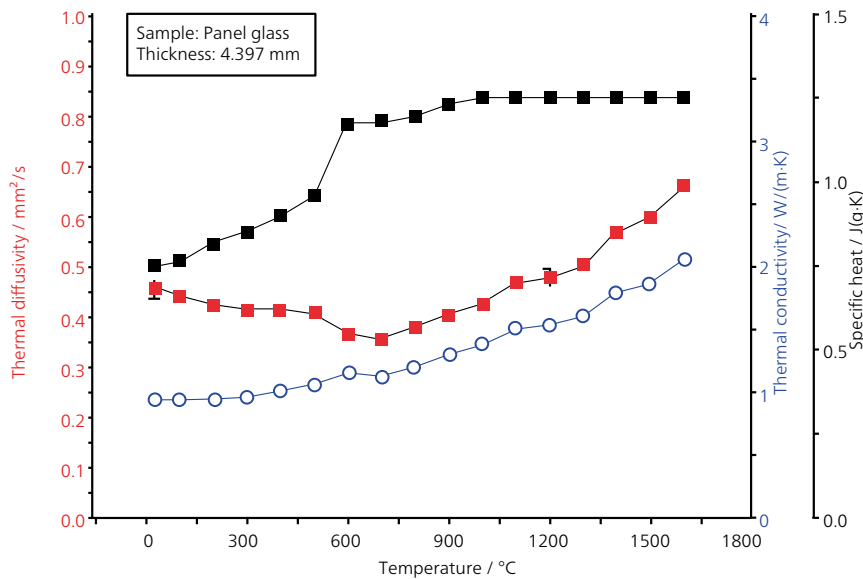

LFA 427 and DSC 404 **F1** Pegasus® measurements on a CRT panel glass

A graphite coating was necessary to achieve a homogeneous entry of energy on the front side and a homogeneous release of energy from the back side of the glass sample. A radiation model was used in order to take the radiation heat transfer within the glass sample into consideration.

The specific heat and thermal diffusivity exhibit a step above the temperature of 500°C. The thermal conductivity increases continuously. This is typical for a glass transition and demonstrates the good agreement between measurements taken with two different devices (LFA 427 and DSC 404 **F1** Pegasus®).

This example clearly demonstrates that the LFA 427 can analyze samples with undefined dimensions (above the softening point) and samples with a high degree of transparency at high temperatures without any problems.



## Sample Holder for Liquid Metals ("Sapphire-C")

The characterization of liquids, pastes and melts is becoming increasingly important in state-of-the-art industrial applications. For measurements on metals in the solid and liquid region, a specific sample holder is available (order no. 6.256.1-93.2.00). The special design of this sample holder makes any multi-layer analysis of the measurement unnecessary.

The sample holder can be used for the LFA 427 and LFA 457 *MicroFlash*<sup>®</sup> systems. The sapphire parts which are in direct contact with the sample can be used for the LFA 447 *NanoFlash*<sup>®</sup>.

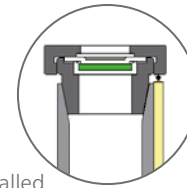
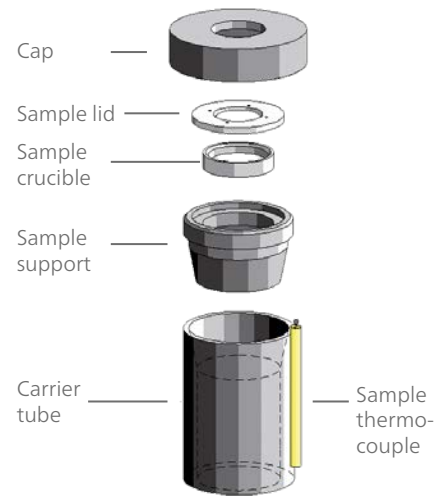

Sample installed

The set up of the sample holder for liquid metals requires no multi-layer analysis of the test results.

## Magnesium Aluminum Alloy

In this plot, the measurement results for the thermophysical properties of a magnesium aluminum alloy are presented. The LFA measurements were carried out using the sample holder for liquid metals. The sapphire container ensures that the dimensions of the liquid remain defined.

The thermal diffusivity and thermal conductivity exhibit a nearly linear decrease above room temperature. A typical step in the thermal diffusivity/conductivity was detected for the phase transition (solid/liquid) above 550°C. The reason is the dissolution of the lattice structure during the phase transition, resulting in a reduced electronic heat transfer.

The example clearly demonstrates that the LFA method can easily analyze liquid metals.

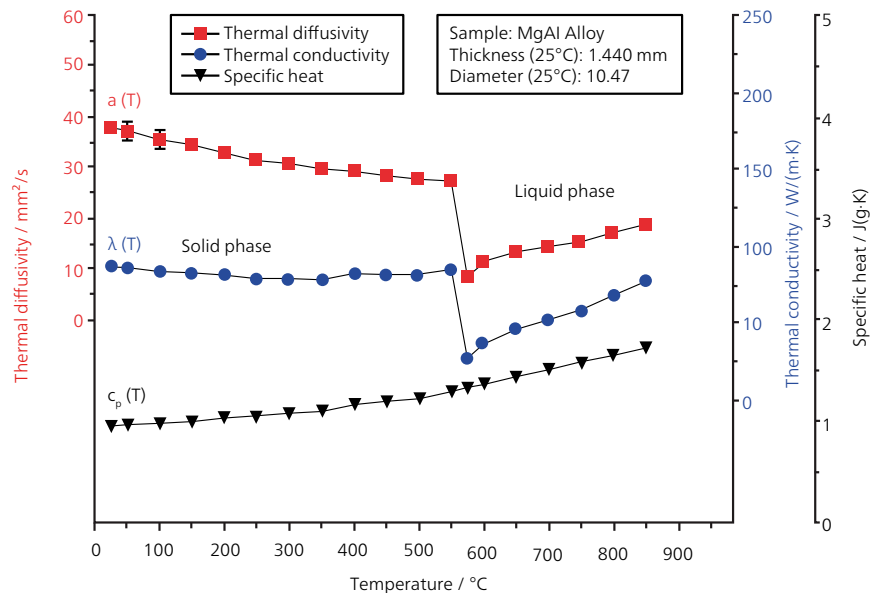

LFA 457 *Microflash*<sup>®</sup> measurement on an MgAl alloy between room temperature and 850°C. During melting, the thermophysical properties drastically change. The specific heat was determined with the DSC 404 *F1 Pegasus*<sup>®</sup>.

## Sample Holder for In-Plane Measurements on Thin, Highly Conductive Materials

The sample holder for in-plane measurements ensures uncomplicated sample preparation. It can be used for materials with high thermal conductivity (e.g., metals, ceramics, graphite, etc.) and for thin samples with a thickness of less than 1 mm. The set comes with an inset and cap made of stainless steel. The sample dimensions can vary in diameter from 20 mm to 25.4 mm.

It is available for:

- LFA 447 *NanoFlash*®  
order no. NIB008171
- LFA 457 *MicroFlash*®,  
LFA467 *HyperFlash*®, LFA 427  
order no. 6.257.1-91.2.00

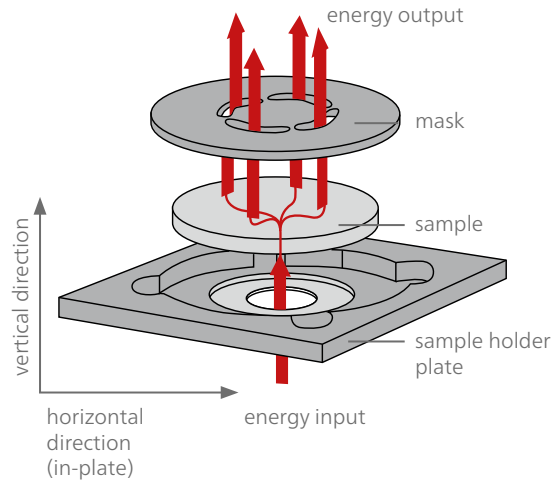

Heat flow directions using the in-plane sample holder. The special set-up of the in-plane sample holder eliminates the typical measurement limitations caused by the minimum sample thickness.

## Thin, Highly Conductive Samples – Metal Films

Metal foils are essential for a broad range of applications in industries such as packaging and electronics. They can be used as electrical contacts in electronic devices or heat sinks, and as base plates in automotive and high-power electronics. In applications such as these, special thermophysical properties such as high thermal conductivity and low thermal expansion are required. This plot shows LFA measurements on two thin metal foils. Using the in-plane sample holder, the thermal diffusivity was determined in the horizontal film direction. The special set-up of the in-plane sample holder eliminates the typical measurement limitations caused by the minimum sample thickness.

Both metal foils exhibit typical decreasing thermal diffusivity values with increasing temperature.

The accuracy of the results obtained was verified with further LFA measurements using the sample holder for lamellar. For this purpose, the samples were sliced into strips 2 mm thick and rotated 90°. For the measurement, the same direction was adjusted.

The deviation between the results is less than 3%. This example clearly demonstrates that metal foils with a high thermal conductivity can be easily analyzed with the LFA 447 *NanoFlash*® – even if they are only a few microns thick.

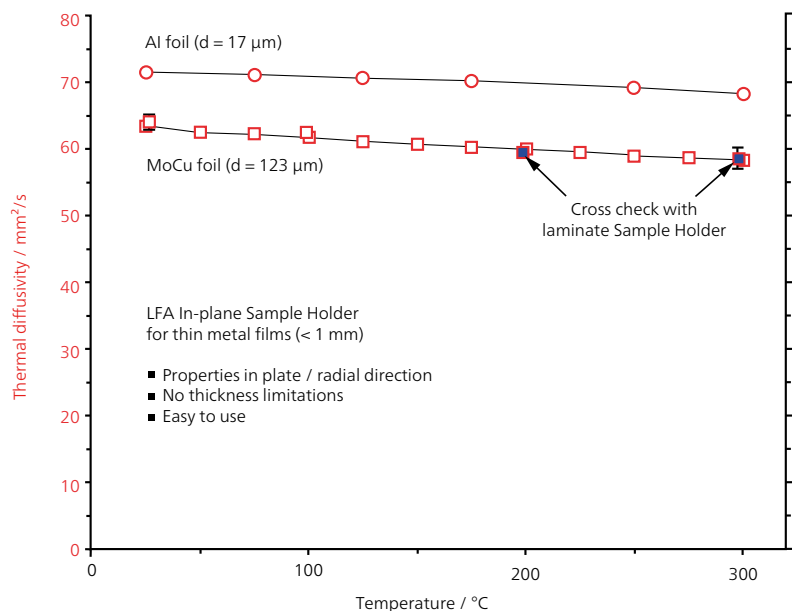

LFA 447 *Nanoflash*®: In-plane measurements on thin aluminum and MoCu metal foils

## Pressure Sample Holder

Due to the special structure of fibrous materials, their thermophysical properties are dependent not only on temperature but on pressure as well. NETZSCH therefore developed a special pressure sample holder which allows calibrated pressures up to 5 MPa and measurements up to 300°C.

The sample is measured between two metal plates. The measurement is evaluated using the 3-layer model which is integrated into the software. This sample holder set comes with a torque wrench for 60 Ncm to 260 Ncm.

The pressure sample holder set is available for:

- LFA 447 *NanoFlash*®  
order no. 6.257.1-91.1
- LFA 457 *MicroFlash*®,  
LFA 467 *HyperFlash*®  
order no. 6.257.1-91.9.00
- LFA 427  
order no. 6.256.4-92.8.00

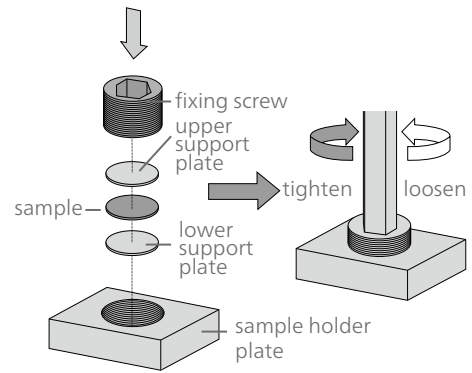

Individual components of the pressure sample holder



Order no. 6.257.1-91.1 for LFA 447 *NanoFlash*®

## Carbon Fiber Composite

Carbon fiber is a material with high tensile strength, high tensile modulus and many other excellent properties. The potential applications of carbon fiber are virtually limitless. In order to optimize this potential, it is necessary to be knowledgeable about the thermo-physical properties of the material. This application shows the LFA measurement results on two carbon fiber samples at room temperature as a function of mechanical pressure. The special pressure sample holder was used. The observed behavior of the thermal conductivity as a function of pressure is typical for compressible fiber structures. The dominant heat transfer contributions (lattice structure, gas phase, radiation, interactions) and thermal contact resistances within the fiber structure change with increasing pressure.

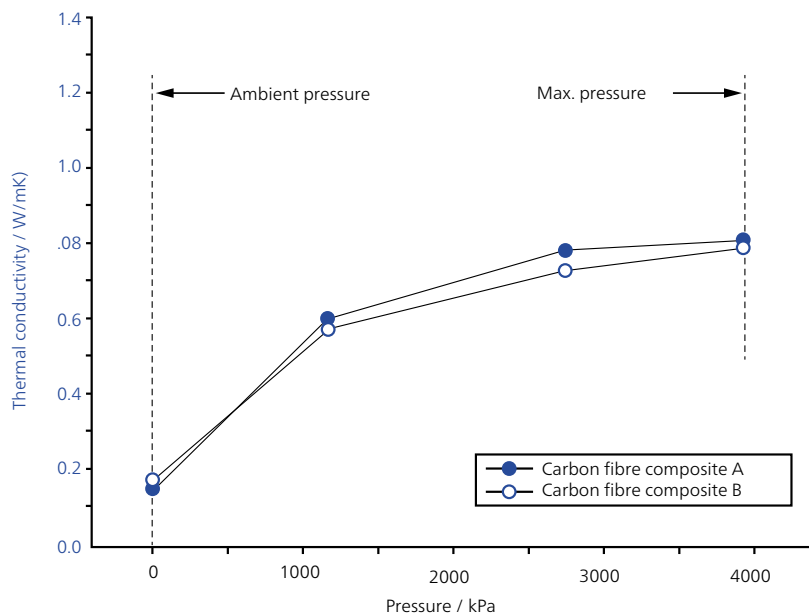

LFA 457 *Microflash*® measurements on two carbon fibers (2 mm thick) between ambient and 4 MPa in air at room temperature.

## Fiber Sample Holder

For measurements on fibers in the fiber direction, special sample holders are available for the following instruments:

- LFA 457 *MicroFlash*<sup>®</sup>  
(order no. 6.257.1-93.1.00)
- LFA 427  
Al<sub>2</sub>O<sub>3</sub> version:  
order no. 6.256.1-93.3.00;  
graphite version:  
order no. 6.256.1-93.6.00

The sample holder set consists of two half-shells and a fixing ring. Use of the appropriate tool set (order no. 6.256.193.4.00) makes preparation of the fiber package in the sample holder quite simple.

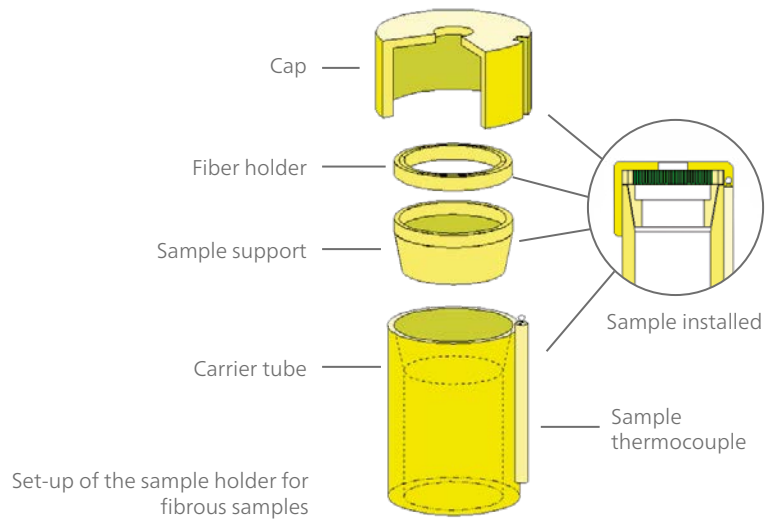

LFA 457 *MicroFlash*<sup>®</sup> sample holder for fibrous samples

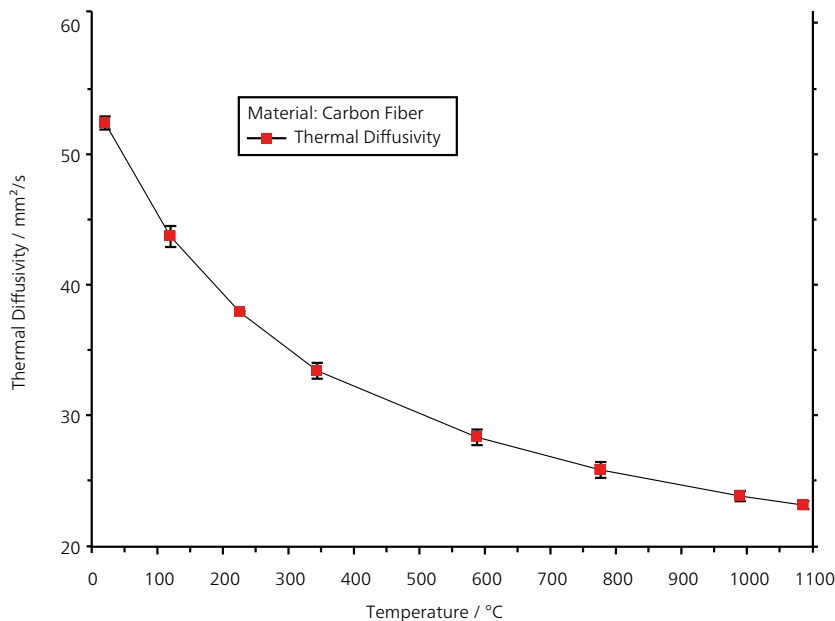

Thermal diffusivity of a carbon fiber material

## Carbon Fiber

This plot shows an LFA 457 *MicroFlash*<sup>®</sup> measurement on a carbon fiber material from room temperature to 1100°C. The thermal diffusivity was determined in the fiber direction.

It can be clearly observed that the thermal diffusivity decreases with increasing temperature, from 53 mm<sup>2</sup>/s at RT down to 24 mm<sup>2</sup>/s by the end of the measurement.

## Sample Holder for Lamellar Samples

For the analysis of anisotropic materials, a special sample holder is available. This sample holder allows for measurements on thin metal or polymer plates in the plate direction. Following the measurement, the plates can be taken out of the sample holder and rotated by 90°, then reinserted. Such repositioning allows, for example, the anisotropy of a piece of rolled sheet metal to be studied. The sample support and cap are made of graphite. The individual lamellas are compressed to a total sample size of 10 mm x 10 mm with clamping screws. The screws are made of graphite as well. Measurements above 300°C require an inert atmosphere.

The sample holder for lamellar samples is available for:

- LFA 447 *NanoFlash*®  
10mm<sup>2</sup>: order no. NIB008506/NIB007593  
12.7 mm<sup>2</sup>: order no. NIB008503/NIB006806
- LFA 467 *HyperFlash*®  
order no. LFA46700A90.052-00
- LFA 457 *MicroFlash*®  
order no. 6.257.1-90.8.00
- LFA 427  
order no. 6.256.1-91.9.00

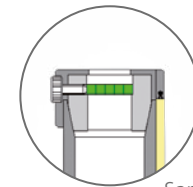
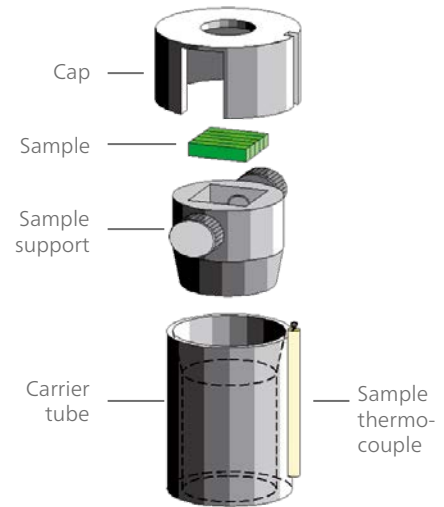

Sample installed

LFA 457 *Microflash*® sample holder for lamellar samples, order no. 6.257.1-90.8.00

LFA 427 sample holder set-up for lamellar samples, order no. 6.256.1-91.9.00

## Thermal Diffusivity in Different Plate Directions

For this analysis of the anisotropic behavior of a PPS+C sample, the lamellar sample holder was used. The measurements were carried out from room temperature to 150°C.

It can clearly be seen that the thermal diffusivity and thermal conductivity values for the normal plate direction are approximately three times lower than those for the in-plane direction. In addition, the in-plane thermal diffusivity decreases sharply from about 7 mm<sup>2</sup>/s at room temperature down to 5 mm<sup>2</sup>/s at 150°C. This is a much steeper drop than that of the thermal diffusivity behavior in the normal plate direction.

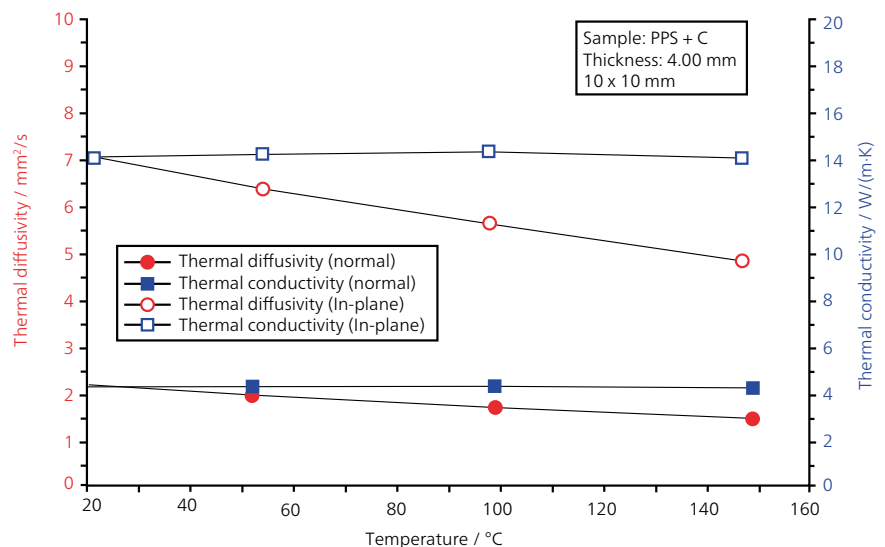

LFA 427 measurement on a PPS+C sample in the sample holder for lamellar samples

## Sample Holder for Shrinking/Crumbling Samples

For measurements on samples which are known for their tendency to shrink or crumble away during heating, several sample holders made of wire mesh are available. These sample holders can be ordered with mesh widths of 4 mm or 2.75 mm and can be made of either tungsten or Pt30%Rh.

They fit into  $\text{Al}_2\text{O}_3$  sample holders with a diameter of 12.7 mm.

Such sample holders are very well suited for the study of ceramic materials such as green bodies, which usually exhibit a distinctive shrinkage behavior during the sintering process.

This sample holder is available for the LFA 457 *Microflash*<sup>®</sup> and LFA 427:

- Tungsten/4 mm mesh width: order no. NGB812129
- Tungsten/2.75 mm mesh width: order no. NGB812130
- Pt30%Rh/4 mm mesh width: order no. 6.257.1-94.4.01
- Pt30%Rh/2.75 mm mesh width: order no. 6.257.1-94.4.02

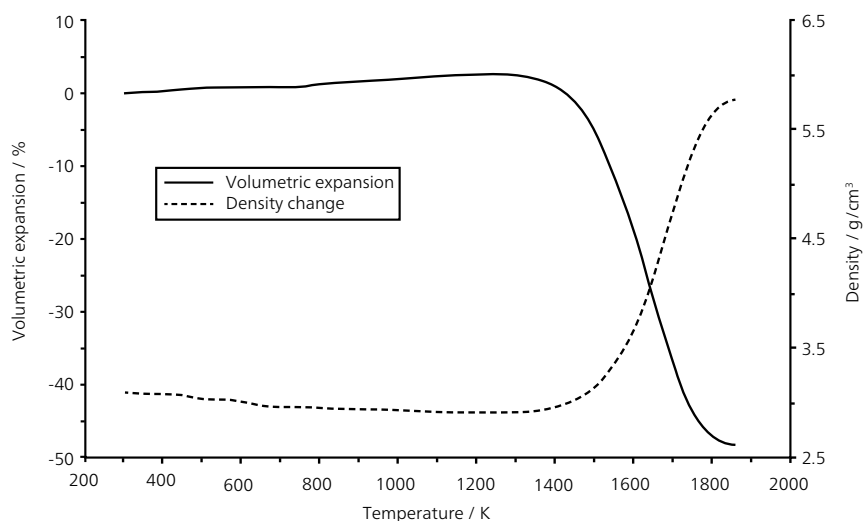

Volumetric expansion and density change of a zirconium oxide

## Zirconium Oxide Green Body

This plot shows the characterization of the thermophysical properties of a zirconium sample. The sintering process was analyzed with a dilatometer measurement (upper plot). The influence of the binder burnout results in a slight density decrease between 300°C and 500°C. During sintering, the density increases to approx. 5.8 g/cm<sup>3</sup> at 1600°C (upper plot). The decrease in the volumetric expansion already shows the ceramic's drastic shrinkage behavior during sintering.

In these cases, the special LFA sample holder for shrinking crumbling samples maintains the sample's position within the sample holder, thus allowing the LFA measurement to be continued through the end of the sintering process.

Here, the thermal diffusivity was first measured on the green body with binder (lower plot). The thermal diffusivity was approx.  $0.24 \text{ mm}^2/\text{s}$  at room temperature and decreased slightly with increasing temperature. Above  $300^\circ\text{C}$ , a decrease in the measured data of approx. 50% can be observed. The binder reduces the thermal contact resistances between the particles. Due to the decomposition of the binder, this contact medium is eliminated and the influence of the thermal contact resistances increases.

In the same temperature range, the debinded material clearly shows the influences of the binder on the transport properties of the material. The thermal diffusivity is significantly lower.

Between  $500^\circ\text{C}$  and  $800^\circ\text{C}$ , a continuous increase in the thermal diffusivity takes place. A possible reason for this rise could be the beginning of the formation of sintering necks between the powder particles. In the range of the main shrinkage (volume sintering), an increase in the thermal diffusivity's temperature dependence can be seen.

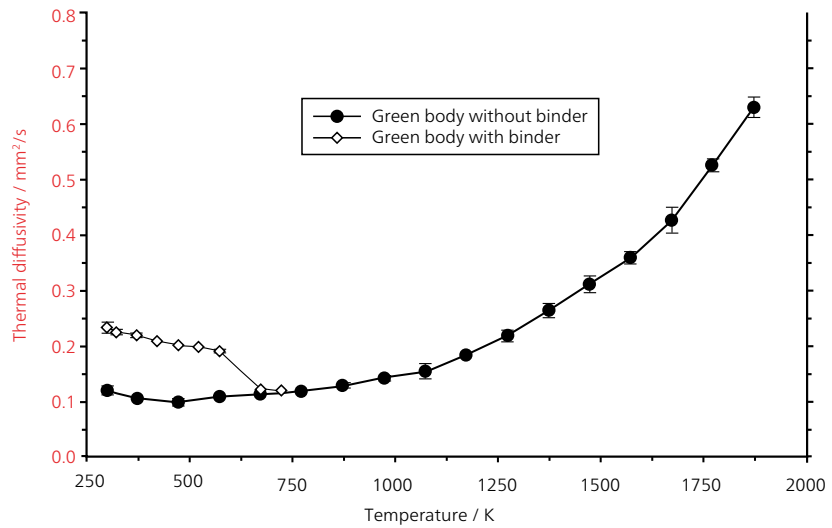

Thermal diffusivity of zirconium oxide green bodies measured in the LFA 427

# Reference Materials

## Reference Materials – Sets and Individual Materials

Please note when using reference samples with special dimensions that it is essential to maintain a diameter-to-thickness ratio of  $>5$ . Lower ratios might decrease accuracy. To ensure reliable test results, the thermal diffusivity should fall within  $\pm 3\%$  in terms of accuracy.

The following tables show sets and individual reference materials for the determination of thermal diffusivity and specific heat ( $c_p$ ).

Recommended reference materials are listed separately from those which differ in dimensions. These reference materials should be used to evaluate the diameter-to-thickness prior to the LFA measurement. Please consider to adjust the reference materials to the sample holder you selected.



Set of Reference Materials				
Materials	Shape	Order Number Individual Materials	Dimension Diameter/ Edge Length x Thickness	Order No. Set
Pyroceram	Round	NIB008776	12.7 mm x 2.5 mm	6.256.1-99.0.00
POCO		NIB008785		
Stainless steel		6.256.4-94.2.04		
Copper		6.256.4-96.2.04		
Pyroceram	Round	NIB007164	10.0 mm x 2.0 mm	6.256.1-96.0.00
Graphite POCO		NIB007162		
Stainless steel		6.256.4-94.3.02		
Copper		6.256.4-96.3.02		
Pyroceram	Square	NIB007176	10.0 mm x 10.0 mm x 2.0 mm	6.256.1-95.0.00
Graphite POCO		NIB007174		
Stainless steel		6.256.4-94.6.02		
Copper		6.256.4-96.6.02		
Pyroceram	Round	NIB008776	12.7 mm x 2.5 mm	6.256.6-94.0.00
Graphite POCO		NIB008785		
Inconel 600		6.256.4-93.2.04		



Recommended Reference Materials for Determination of the Thermal Diffusivity and Specific Heat ( $c_p$ )

Material Shape	Dimension Diameter/ Edge Length x Thickness	Order Number	Material Shape	Dimension Diameter/ Edge Length x Thickness	Order Number
<b>Pyroceram 9606 (a @ RT = 1.926 mm<sup>2</sup>/s)</b>			<b>Molybdenum (a @ RT = 54.3 mm<sup>2</sup>/s)</b>		
Round	25.4 mm x 2.5 mm	NIB008774	Round	25.4 mm x 2.5 mm	6.257.1-97.1.04
	20.0 mm x 2.5 mm	NIB008775		12.7 mm x 2.5 mm	6.256.4-97.2.04
	12.7 mm x 2.5 mm	NIB008776		10.0 mm x 2.0 mm	NIB007449
	10.0 mm x 2.0 mm	NIB007164		12.7 mm x 12.7 mm x 2.5 mm	6.257.1-97.10.04
Square	12.7 mm x 12.7 mm x 2.5 mm	NIB008777	Square	10.0 mm x 10.0 mm x 2.0 mm	NIB007458
	10.0 mm x 10.0 mm x 2.0 mm	NIB007176		10.0 mm x 10.0 mm x 2.0 mm	NIB007176
<b>Stainless Steel (a @ RT = 3.352 mm<sup>2</sup>/s)</b>			<b>Tungsten (a @ RT = 69.3 mm<sup>2</sup>/s)</b>		
Round	25.4 mm x 2.5 mm	6.256.4-94.1.04	Round	12.7 mm x 2.5 mm	6.256.4-98.2.04
	20.0 mm x 2.5 mm	6.256.4-94.9.04		10.0 mm x 2.0 mm	6.256.4-98.3.02
	12.7 mm x 2.5 mm	6.256.4-94.2.04	Square	12.7 mm x 12.7 mm x 2.5 mm	6.256.4-98.10.04
	10.0 mm x 2.0 mm	6.256.4-94.3.02		10.0 mm x 10.0 mm x 2.0 mm	6.256.4-98.6.02
Square	12.7 mm x 12.7 mm x 2.5 mm	6.256.4-94.10.04	<b>Inconel 600 (a @ RT = 3.458 mm<sup>2</sup>/s)</b>		
	10.0 mm x 10.0 mm x 2.0 mm	6.256.4-94.6.02	Round	12.7 mm x 2.5 mm	6.256.4-96.2.04
<b>Inconel 600 (a @ RT = 3.458 mm<sup>2</sup>/s)</b>				10.0 mm x 2.0 mm	6.256.4-96.3.02
Round	25.4 mm x 2.5 mm	6.256.4-93.1.04	Square	10.0 mm x 10.0 mm x 2.0 mm	6.256.4-96.6.02
	20.0 mm x 2.5 mm	6.256.4-93.9.04			
	12.7 mm x 2.5 mm	6.256.4-93.2.04			
	10.0 mm x 2.0 mm	6.256.4-93.3.02			
Square	12.7 mm x 12.7 mm x 2.5 mm	6.256.4-93.10.04			
	10.0 mm x 10.0 mm x 2.0 mm	6.256.4-93.6.02			



Set of 4 reference materials

LFA 447 NanoFlash®

LFA 467 HyperFlash®

LFA 467 HT HyperFlash®

LFA 457 MicroFlash®

LFA 427

**Individual Reference Materials for Determination of the Thermal Diffusivity and Specific Heat ( $c_p$ )**

Material Shape	Dimension Diameter/ Edge Length x Thickness	Order Number	Material Shape	Dimension Diameter/ Edge Length x Thickness	Order Number
<b>Pyroceram 9606</b>			<b>Inconel 600</b>		
Round	25.4 mm x 1.0 mm	NIB007138	Round	25.4 mm x 1.0 mm	6.256.4-93.1.01
	12.7 mm x 1.0 mm	NIB007150		12.7 mm x 1.0 mm	6.256.4-93.2.01
	10.0 mm x 1.0 mm	NIB007160		12.7 mm x 2.5 mm	6.256.4-93.2.04
	8.0 mm x 2.0 mm	NIB007827		10.0 mm x 1.0 mm	6.256.4-93.3.01
	6.0 mm x 1.0 mm	NIB007645		10.0 mm x 10.0 mm x 1.0 mm	6.256.4-93.6.01
	6.0 mm x 2.0 mm	NIB007567		Square	8.0 mm x 8.0 mm x 1.0 mm
Square	12.7 mm x 12.7 mm x 1.0 mm	NIB007607	8.0 mm x 8.0 mm x 2.0 mm	6.256.4-93.7.02	
	10.0 mm x 10.0 mm x 1.0 mm	NIB007172	<b>Molybdenum</b>		
	8.0 mm x 8.0 mm x 1.0 mm	NIB007184	Round	25.4 mm x 1.0 mm	NIB007496
	8.0 mm x 8.0 mm x 2.0 mm	NIB007188		12.7 mm x 1.0 mm	NIB007451
	6.0 mm x 6.0 mm x 1.0 mm	NIB007473		10.0 mm x 1.0 mm	NIB007448
	6.0 mm x 6.0 mm x 2.0 mm	NIB007474	Square	10.0 mm x 10.0 mm x 1.0 mm	NIB007457
<b>Stainless Steel</b>				8.0 mm x 8.0 mm x 1.0 mm	NIB007454
25.4 mm x 1.0 mm	6.256.4-94.1.01	8.0 mm x 8.0 mm x 2.0 mm		NIB007455	
Round	12.7 mm x 1.0 mm	6.256.4-94.2.01	<b>Copper (99.999%)</b>		
	12.7 mm x 2.5 mm	6.256.4-94.2.04	Round	25.4 mm x 2.5 mm	6.256.4-96.1.04
	10.0 mm x 1.0 mm	6.256.4-94.3.01		12.7 mm x 1.0 mm	6.256.4-96.2.01
	10.0 mm x 2.0 mm	6.256.4-94.3.02		12.7 mm x 2.5 mm	6.256.4-96.2.04
	10.0 mm x 10.0 mm x 1.0 mm	6.256.4-94.6.01		10.0 mm x 1.0 mm	6.256.4-96.3.01
8.0 mm x 8.0 mm x 1.0 mm	6.256.4-94.7.01	Square		10.0 mm x 10.0 mm x 1.0 mm	6.256.4-96.6.01
8.0 mm x 8.0 mm x 2.0 mm	6.256.4-94.7.02		10.0 mm x 10.0 mm x 2.0 mm	6.256.4-96.6.02	
			8.0 mm x 8.0 mm x 1.0 mm	6.256.4-96.7.01	
			8.0 mm x 8.0 mm x 2.0 mm	6.256.4-96.7.02	

to "Materials for Temperature Verification" (page 45):  
 The material should only be used for temperature verification. Determination of the Curie temperature (magnetic transformation) can be realized by detecting the minimum of the thermal diffusivity at  $b = 768^\circ\text{C}$ . If possible, the measurement should be carried out in a graphite-free atmosphere without any graphite coating on the sample in order to prevent "carbonization" (diffusion of C-atoms in the lattice structure), which might cause changes of the thermo-physical properties. We recommend to sandblast the surface.

Reference Materials for Determination of the Specific Heat

Material Shape	Dimension Diameter/ Edge Length x Thickness	Order Number	Material Shape	Dimension Diameter/ Edge Length x Thickness	Order Number
<b>Graphite POCO</b>			<b>Pyrex 7740</b>		
Round	25.4 mm x 1.0 mm	NIB007136	Round	12.7 mm x 1.0 mm	NIB007149
	25.4 mm x 2.5 mm	NIB008783		12.7 mm x 2.0 mm	NGB825235
	20.0 mm x 2.5 mm	NIB008784		10.0 mm x 1.0 mm	NIB007159
	12.7 mm x 1.0 mm	NIB007519		10.0 mm x 2.0 mm	NIB007163
	12.7 mm x 2.5 mm	NIB008785		6.0 mm x 1.0 mm	NIB007642
	10.0 mm x 1.0 mm	NIB007522		6.0 mm x 2.0 mm	NIB007643
	10.0 mm x 2.0 mm	NIB007162	Square	10.0 mm x 10.0 mm x 1.0 mm	NIB007171
	6.0 mm x 1.0 mm	NIB007633		10.0 mm x 10.0 mm x 2.0 mm	NIB007175
	6.0 mm x 2.0 mm	NIB007634		8.0 mm x 8.0 mm x 1.0 mm	NIB007183
12.7 mm x 12.7 mm x 1.0 mm	NIB007623	8.0 mm x 8.0 mm x 2.0 mm		NIB007187	
12.7 mm x 12.7 mm x 2.5 mm	NIB008786	6.0 mm x 6.0 mm x 1.0 mm		NIB007470	
10.0 mm x 10.0 mm x 1.0 mm	NIB007525	6.0 mm x 6.0 mm x 2.0 mm	NIB007471		
Square	10.0 mm x 10.0 mm x 2.0 mm	NIB007174	<b>Reference Materials for Temperature Verification</b>		
	8.0 mm x 8.0 mm x 1.0 mm	NIB007528	Material Shape	Dimension Diameter/ Edge Length x Thickness	Order Number
	8.0 mm x 8.0 mm x 2.0 mm	NIB007529	<b>Pure Iron</b>		
	6.0 mm x 6.0 mm x 1.0 mm	NIB007467	Round	25.4 mm x 2.5 mm	6.256.4-95.1.04
	6.0 mm x 6.0 mm x 2.0 mm	NIB007468		20.0 mm x 2.5 mm	6.256.4-95.9.04
<b>Alumina (99.8%)</b>				12.7 mm x 2.5 mm	6.256.4-95.2.04
Round	25.4 mm x 1.0 mm	NIB007139		10.0 mm x 2.0 mm	6.256.4-95.3.02
	25.4 mm x 2.5 mm	NIB008778		8.0 mm x 2.0 mm	6.256.4-95.4.02
	12.7 mm x 1.0 mm	NIB007151		6.0 mm x 2.0 mm	6.256.4-95.5.02
	12.7 mm x 2.5 mm	NIB008779	Square	12.7 mm x 12.7 mm x 2.5 mm	6.256.4-95.10.04
	10.0 mm x 1.0 mm	NIB007161		10.0 mm x 10.0 mm x 2.0 mm	6.256.4-95.6.02
	10.0 mm x 2.0 mm	NIB007165		8.0 mm x 8.0 mm x 2.0 mm	6.256.4-95.7.02
	6.0 mm x 1.0 mm	NIB007636		6.0 mm x 6.0 mm x 2.0 mm	6.256.4-95.8.02
	6.0 mm x 2.0 mm	NIB007637		<b>Reference Materials for Determination of the Specific Heat</b>	
Square	12.7 mm x 12.7 mm x 1.0 mm	NIB007624	Material Shape	Dimension Diameter/ Edge Length x Thickness	Order Number
	12.7 mm x 12.7 mm x 2.5 mm	NIB008781	<b>Pure Iron</b>		
	10.0 mm x 10.0 mm x 1.0 mm	NIB007173	Round	25.4 mm x 2.5 mm	6.256.4-95.1.04
	10.0 mm x 10.0 mm x 2.0 mm	NIB007177		20.0 mm x 2.5 mm	6.256.4-95.9.04
	8.0 mm x 8.0 mm x 1.0 mm	NIB007185		12.7 mm x 2.5 mm	6.256.4-95.2.04
	8.0 mm x 8.0 mm x 2.0 mm	NIB007189		10.0 mm x 2.0 mm	6.256.4-95.3.02
	6.0 mm x 6.0 mm x 1.0 mm	NIB007464		8.0 mm x 2.0 mm	6.256.4-95.4.02
6.0 mm x 6.0 mm x 2.0 mm	NIB007465	6.0 mm x 2.0 mm		6.256.4-95.5.02	

LFA 447 NanoFlash®

LFA 467 HyperFlash®

LFA 467 HT HyperFlash®

LFA 457 MicroFlash®

LFA 427

# Sample Preparation

Fine-Tooth Table Saw		
	Remarks	Order Number
Fine-cut table saw	<p>For the preparation of small samples, consisting of:</p> <ul style="list-style-type: none"> <li>▪ table saw with motor, 220 – 240 V, 50 Hz</li> <li>▪ sliding table</li> <li>▪ cutting length: 100 mm, cutting width: 2 – 32 mm, cutting depth: 2 – 3 mm</li> <li>▪ diamond cutting wheel for filled polymer materials</li> <li>▪ standard saw blade for normal polymer materials</li> </ul> <p>Note: For the connection to 115 V, 50/60 Hz, a step-down transformer is required, order no. NGB803116</p>	6.445.1-00.0.00
Diamond cutting wheel	Diameter of 75 x width 1.1 mm	NGB803926
Standard saw blade	Diameter of 80 x width 1.6 mm, 24 teeth	NGB803921

Tapping Hole Drilling Machine		
	Remarks	Order Number
Tapping hole drilling machine	<p>For the preparation of small samples, consisting of:</p> <ul style="list-style-type: none"> <li>▪ drilling and milling stand</li> <li>▪ milling motor</li> <li>▪ power supply 220 – 240 V, 50/60 Hz</li> <li>▪ retainer for diamond</li> <li>▪ tapping hole drills</li> <li>▪ diamond tapping hole drill for samples with a diameter of approx. 12.5 mm for filled polymer materials</li> <li>▪ standard tapping hole drill for samples with a diameter of approx. 12.5 mm for normal polymer materials</li> </ul>	6.445.2-00.0.00
Standard hollow drill	For a sample with a diameter of 12.5 mm, with clamping pivot diameter of 6 mm	6.445.2-02.0.00
Standard hollow drill	For a sample with a diameter of 25.4 mm, with clamping pivot diameter of 6 mm	6.445.2-04.0.00
Diamond hollow drill	For a sample with a diameter of 10 mm, with clamping adaptor diameter of 6 mm	6.445.2-07.0.00
Diamond hollow drill	For a sample with a diameter of 12.5 mm, with clamping adaptor diameter of 6 mm	6.445.2-03.0.00
Diamond hollow drill	Inner diameter of 12.7 mm, outer diameter of 14.7 mm, drilling depth max. 60 mm	NGB803927
Diamond hollow drill	For a sample with a diameter of 25.4 mm, with clamping adaptor diameter of 6 mm	6.445.2-05.0.00
Diamond hollow drill	For a sample with a diameter of 25.4 mm	NGB804742
Step-up transformer	800 VA, primary 115 V, secondary 230 V, in single enclosure	NGB803116

Sputter Coater for Sample Preparation		
	Remarks	Order Number
Sputter coater	DENTON coater, inner diameter of 6", without target (separate order required), two-stage rotary vane pump of 4 m <sup>3</sup> /h included; input power of 230 V, 50/60 Hz	6.256.4-92.5.00
Sputter coater	DENTON coater, inner diameter of 6", without target (separate order required), two-stage rotary vane pump of 4 m <sup>3</sup> /h included; input power of 120 V, 50/60 Hz	6.256.4-92.6.00
Gold target	2.375", thickness 0.002"	NGB811178
Gold target	2.375", thickness 0.0025"	NGB811179

# Our Expertise

## Our Measuring Methods

Method	Measurement results	Temperature range	In accordance with the following standards (excerpt)	
Differential Scanning Calorimetry (DSC)	Phase transformation temperatures and enthalpies, specific	-180°C ... 1650°C	ASTM	C351, D3417, D3418, D3895, D4565, E793, E794
			DIN	51004, 51007, 53765, 65467
			DIN EN	728
			ISO	10837, 11357, 11409
High-pressure DSC (up to 15 MPa, 150 bar)	Phase transformation temperatures	-50°C ... 600°C	ASTM	D5483, D6186, E1782, E1858, E2009
Differential Thermal Analysis (DTA)	Phase transformation temperatures	-180°C ... 2000°C	ASTM	C351, D3417, D3418, D3895, D4565, E793, E794
			DIN	51004, 51007
			ISO	10837
Thermogravimetry (TGA, STA)	Mass changes, corrosion, thermal stability	RT ... 2000°C	ASTM	E914, E1131, E1868
			DIN	51006
			ISO	7111, 11358
Gas analysis	Characterization of gases emitted by means of MS, GC-MS or FT-IR, coupled to a TGA or STA	-120°C ... 1650°C		
Dilatometry and TMA	Dimensional changes, coefficients of expansion, density change	-180°C ... 2800°C	ASTM	D696, E228, E831, E1363, E1545, E1824
			DIN	53752
Dynamic-Mechanical Analysis (DMA)	Visco-elastic behavior, coefficient of elasticity	-170°C ... 600°C	ASTM	D4092, D4065, D4473, D5023, D5024, D5026, D5418, E1640, E1867
			DIN EN	53440
			DIN EN ISO	6721
Heat Flow Meter and Guarded Hot Plate	Thermal conductivity of insulating materials	-160°C ... 700°C	ASTM	C177, C518, E1530, F433
			DIN EN	12667, 12939, 13163
			ISO	8301, 8302
Flash Methods	Thermal conductivity and diffusivity	-125°C ... 2000°C	ASTM	E1461
			DIN EN	821
Dielectric Analysis	Curing behavior of reactive polymers	RT ... 400°C	ASTM	E2038, E2039

LFA 447 NanoFlash®

LFA 467 HyperFlash®

LFA 467 HT HyperFlash®

LFA 457 MicroFlash®

LFA 427



# Expertise in Service

## Our Expertise – Service

All over the world, the name NETZSCH stands for comprehensive support and reliable service, before and after sale. Our qualified personnel from the technical service and application departments are always available for consultation.

In special training programs tailored for you and your employees, you will learn to tap the full potential of your instrument.

To maintain and protect your investment, you will be accompanied by our experienced service team over the entire life span of your instrument.

## Our Expertise – Applications Laboratories

The NETZSCH Thermal Analysis applications laboratories are a proficient partner for nearly any Thermal Analysis issue. Our involvement in your projects begins with proper sample preparation and continues through meticulous examination and interpretation of the measurement results. Our diverse methods and over 30 different state-of-the-art measuring stations will provide ready-made solutions for all your thermal needs.

Within the realm of thermal analysis and the measurement of thermo-physical properties, we offer you a comprehensive line of the most diverse analysis techniques for materials characterization.

Measurements can be carried out on samples of the most varied of geometries and configurations. You will receive high-precision measurement results and valuable interpretations from us in the shortest possible time. This will enable you to precisely characterize new materials and components before actual deployment, minimize risks of failure, and gain decisive advantages over your competitors.

### TECHNICAL SERVICE



Maintenance and Repair



Software Updates



Exchange Service



IQ/OQ Documents



Calibration Service



Spare Part Assistance



Moving Service

### TRAINING



Training



Comprehensive Instrument and Method Training

### LABORATORY



Application Service and Contract Testing



The NETZSCH Group is an owner-managed, international technology company with headquarters in Germany. The Business Units Analyzing & Testing, Grinding & Dispersing and Pumps & Systems represent customized solutions at the highest level. A worldwide sales and service network ensure customer proximity and competent service.

Our performance standards are high. We promise our customers Proven Excellence – exceptional performance in everything we do, proven time and again since 1873.

When it comes to Thermal Analysis, Calorimetry (adiabatic & reaction), the determination of Thermophysical Properties, Rheology and Fire Testing, NETZSCH has it covered. Our 60 years of applications experience, broad state-of-the-art product line and comprehensive service offerings ensure that our solutions will not only meet your every requirement but also exceed your every expectation.

# Proven Excellence. ■

NETZSCH-Gerätebau GmbH  
Wittelsbacherstraße 42  
95100 Selb, Germany  
Tel.: +49 9287 881-0  
Fax: +49 9287 881-505  
at@netzsch.com  
www.analyzing-testing.netzsch.com



**NETZSCH®**

[www.netzsch.com](http://www.netzsch.com)